

## IPP110ecoplus

Sets eco standards for cultivation below room temperature: unmatched energy efficiency, best values for heat-up, cool-down and recovery times.

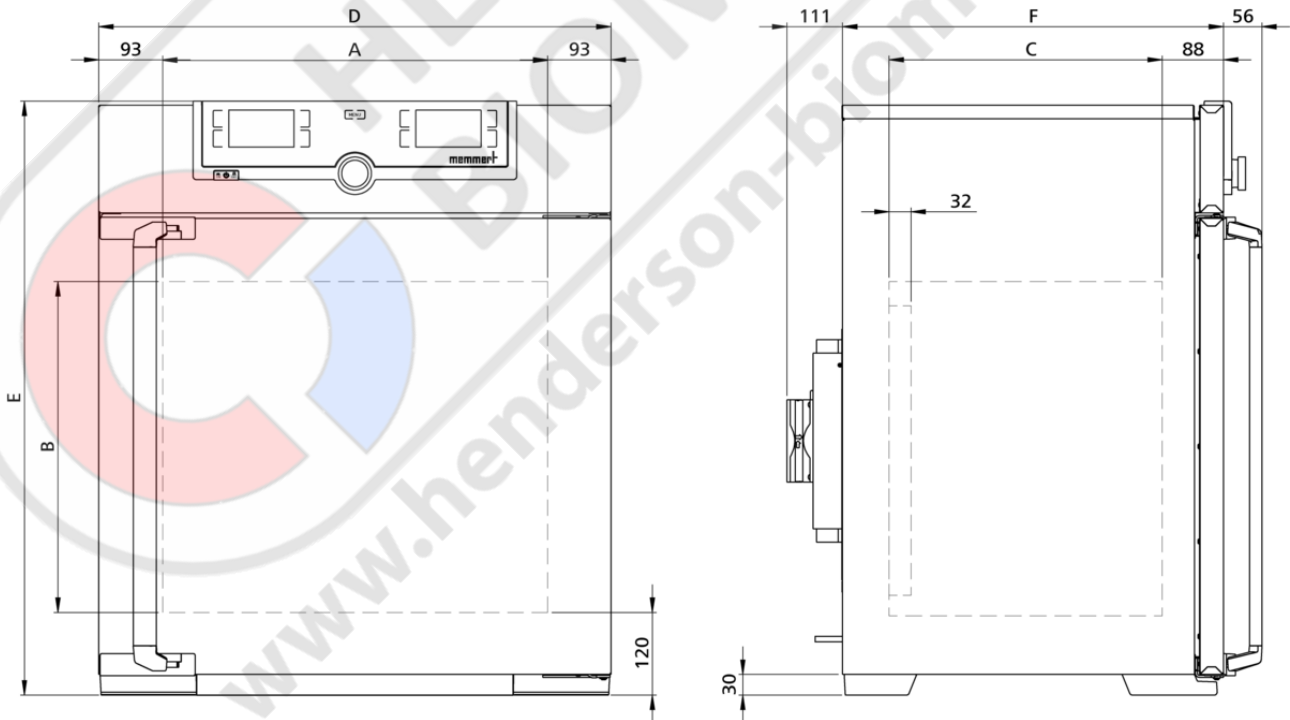

With the help of our model selection, dimensional model sketches and extensive technical data for download, you will find your perfect Peltier-cooled incubator. Flexibility and technical features of our appliances meet all possible needs. Put us to the test!



## Temperature

<b>Setting temperature range</b>	0 to +70 °C
<b>Working temperature range</b>	with light: +10 to +40 °C
<b>Working temperature range</b>	without light: from 0 (at least 20 below ambient temperature) to +70°C
<b>Setting accuracy temperature</b>	0.1 °C
<b>Temperature sensor</b>	2 Pt100 sensors DIN Class A in 4-wire-circuit for mutual monitoring, taking over functions in case of an error

## Control technology

<b>ControlCOCKPIT</b>	TwinDISPLAY. Adaptive multifunctional digital PID-microprocessor controller with 2 high-definition TFT-colour displays.
<b>Language setting</b>	German, English, Spanish, French, Polish, Czech, Hungarian
<b>Timer</b>	Digital backwards counter with target time setting, adjustable from 1 minute to 99 days
<b>Function SetpointWAIT</b>	the process time does not start until the set temperature is reached
<b>Calibration</b>	three freely selectable temperature values
<b>adjustable parameters</b>	temperature (Celsius or Fahrenheit), programme time, time zones, summertime/wintertime

## Ventilation

<b>Convection</b>	forced ventilation by Peltier fan
-------------------	-----------------------------------

## Communication

<b>Documentation</b>	programme stored in case of power failure
<b>Programming</b>	AtmoCONTROL software on a USB stick for programming, managing and transferring programmes via Ethernet interface or USB port

## Safety

<b>Temperature control</b>	over- and undertemperature monitor TWW, protection class 3.3 or adjustable temperature limiter TWB, protection class 2, selectable on display
<b>AutoSAFETY</b>	additionally integrated over- and undertemperature protection "ASF", automatically following the setpoint value at a preset tolerance range, alarm in case of over- or undertemperature, heating function is switched off in case of overtemperature, cooling function in case of undertemperature
<b>Autodiagnostic system</b>	for fault analysis
<b>Alarm</b>	visual and acoustic

## Heating concept

<b>Peltier</b>	Heating and cooling performance distribution by individual control of the Peltier elements in the upper and lower row
<b>Peltier</b>	energy-saving Peltier heating-/cooling system integrated in the rear (heat pump principle)

## Standard equipment

<b>Works calibration certificate</b>	for +10 °C, +25 °C and +40 °C
<b>Door</b>	fully insulated stainless steel door with 2-point locking (compression door lock)
<b>Door</b>	inner glass door
<b>Internals</b>	2 stainless steel grid(s), electropolished

## Stainless steel interior

<b>Dimensions</b>	$w_{(A)} \times h_{(B)} \times d_{(C)}$ : 560 x 480 x 400 mm (d less 32 mm for fan - Peltier)
<b>Volume</b>	108 l
<b>Max. number of internals</b>	5
<b>Max. loading of chamber</b>	150 kg
<b>Max. loading per internal</b>	20 kg

## Textured stainless steel casing

<b>Dimensions</b>	$w_{(D)} \times h_{(E)} \times d_{(F)}$ : 745 x 864 x 555 mm (d +56mm door handle & +111mm Peltier element)
<b>Housing</b>	rear zinc-plated steel

## Electrical data

<b>Voltage</b>	230 V, 50/60 Hz
<b>Electrical load</b>	approx. 320 W
<b>Voltage</b>	115 V, 50/60 Hz
<b>Electrical load</b>	approx. 320 W

## Ambient conditions

<b>Set Up</b>	The distance between the wall and the rear of the appliance must be at least 15 cm. The clearance from the ceiling must not be less than 20 cm and the side clearance from walls or nearby appliances must not be less than 5 cm.
<b>Ambient temperature</b>	16 °C to 40 °C
<b>Humidity rh</b>	max. 70 %, non-condensing
<b>Altitude of installation</b>	max. 2,000 m above sea level
<b>Overvoltage category</b>	II
<b>Pollution degree</b>	2

### Packing/shipping data

<b>Transport information</b>	The appliances must be transported upright
<b>Customs tariff number</b>	8419 8998
<b>Country of origin</b>	Federal Republic of Germany
<b>WEEE-Reg.-No.</b>	DE 66812464
<b>Dimensions approx incl. carton</b>	w x h x d: 830 x 1050 x 800 mm
<b>Net weight</b>	approx. 63 kg
<b>Gross weight carton</b>	approx. 86 kg

Standard units are safety-approved and bear the test marks

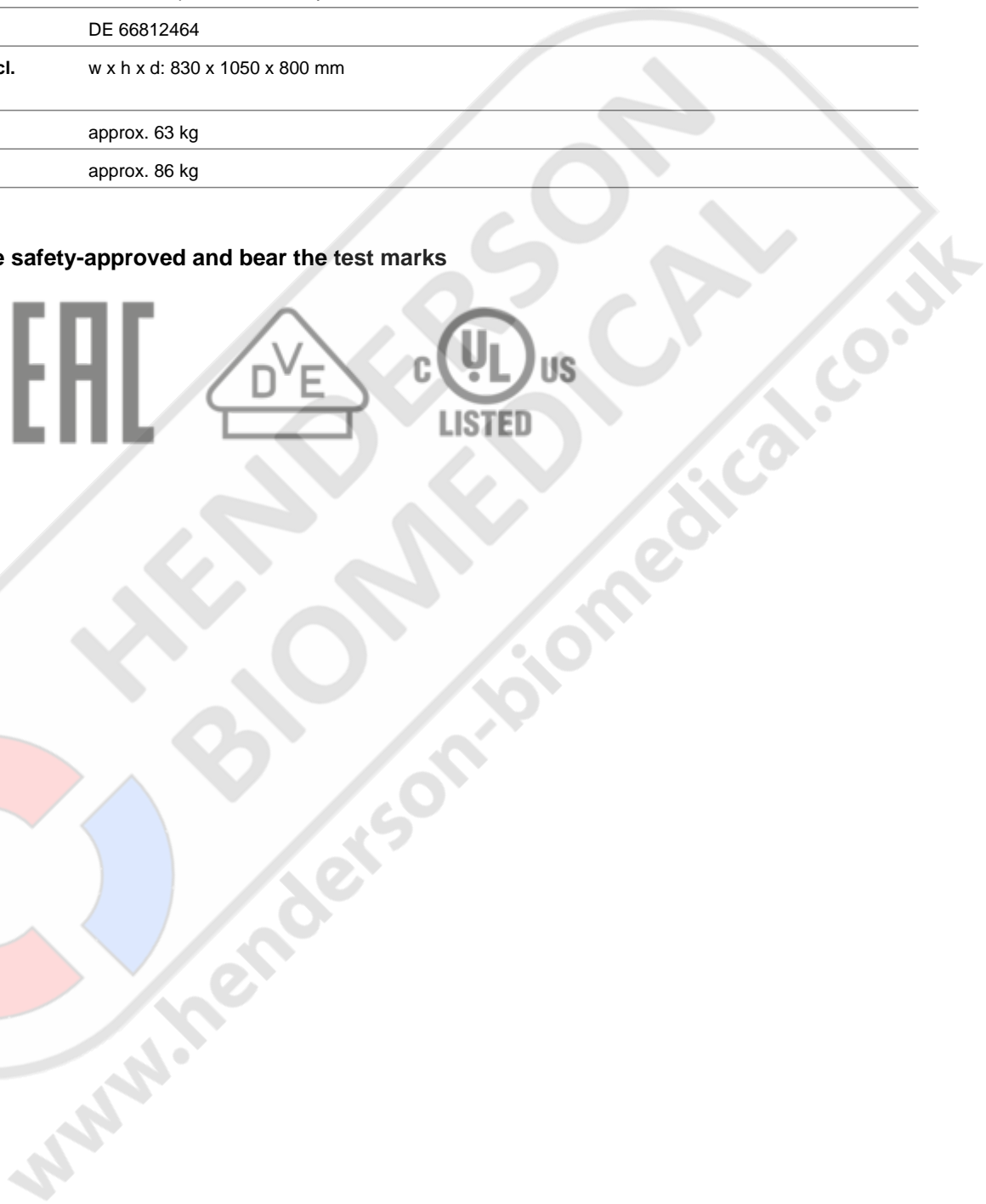



**LABORATORY EQUIPMENT MAINTENANCE, REPAIR, CALIBRATION AND SALES**

Established in 1987, Henderson Biomedical is the UK's leading laboratory equipment sales and service provider. Our knowledgeable team can provide you with excellent sales advice on a range of different types of laboratory equipment including centrifuges, refrigerators, freezers and heat sealers.

Henderson Biomedical is also able to provide you with first class after-sales service and calibration of your laboratory equipment. We are an **ISO 17025 (UKAS) accredited calibration test laboratory** and our team of Field Service Engineers cover the whole of the United Kingdom.

Please contact us for more information on the types of equipment we supply and the different after-sales services we can offer.

**Henderson Biomedical**

Unit 3, Swan Close  
Croydon CR0 2DZ  
United Kingdom

**Tel: 020 8663 4610**

For sales enquiries: [sales@henderson-biomedical.co.uk](mailto:sales@henderson-biomedical.co.uk)  
For all other enquiries: [info@henderson-biomedical.co.uk](mailto:info@henderson-biomedical.co.uk)  
[www.henderson-biomedical.co.uk](http://www.henderson-biomedical.co.uk)

