

User manual - BioPlus - BioMidi

Models: 425, 625, 500, 600/660, 930, 1270/1400

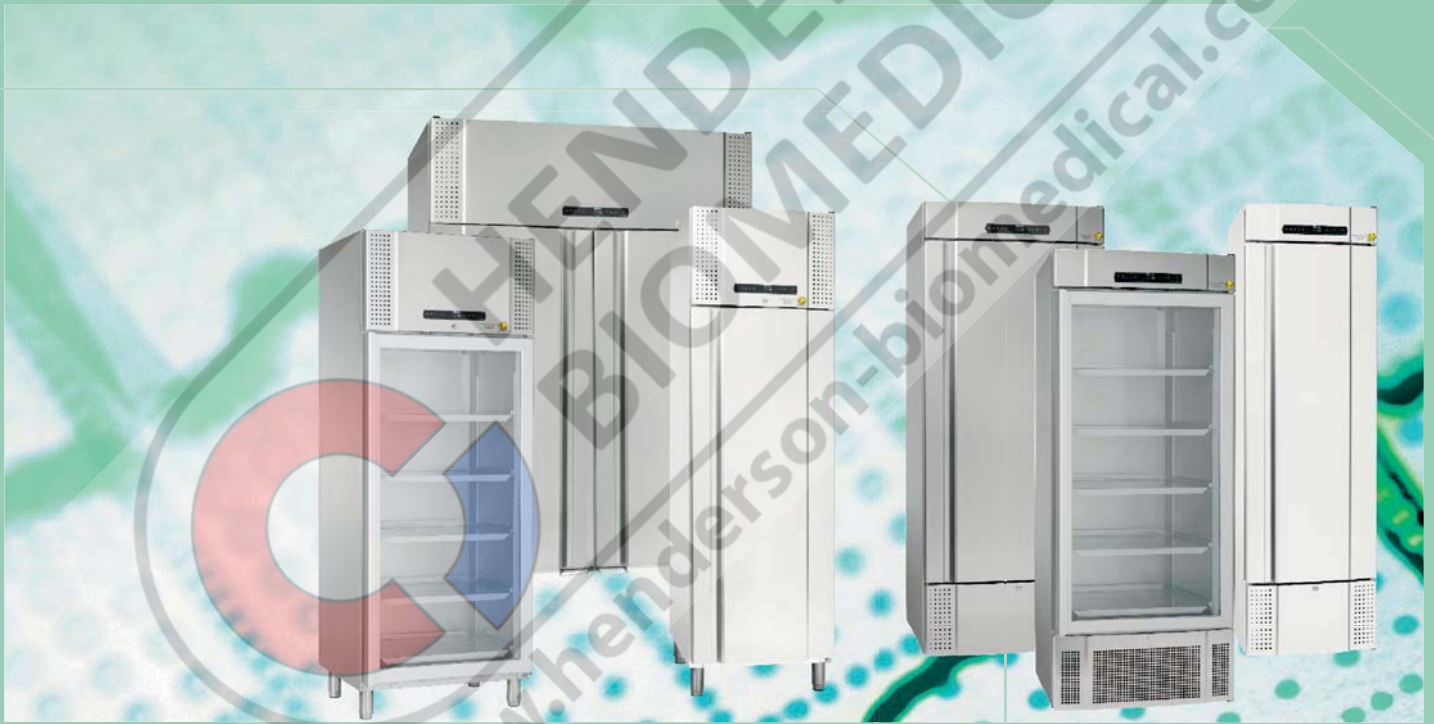

Original User manual

GRAM

Biostorage you can depend on

Table of Content



Table of Content	3
Installation	4
Setting up	4
Voltage-free contact	7
Mechanical low temperature protection	8
Connection to electricity	9
Start-up	10
The digital display	10
Walkthrough of menu	11
Error codes	12
Parameter settings	14
Dry cool	14
Local alarm settings	15
On / Off local door alarm	17
Delay for local door alarm	17
External alarm settings	19
On / Off external door alarm	21
Delay for external door alarm	21
Sensor calibration	23
Escorted / set alarm limits	24
Defrosts / 24 hours	24
Display sensor	25
Electric low temperature protection	26
Reversing of door	28
Ordinary use	30
Regular maintenance	31
Cleaning	31
Door gasket	31

General info	32
Responsibility	32
Service	32
Defrost water	33
Door closing mechanism	33
Access port	34
Important	36
Declaration of conformity	36
Disposal	37

Before you proceed

This user manual is intended for the following product series:

- BioPlus
- BioMidi

We recommend that you read this user manual thoroughly through before using the cabinet.

Your feedback is appreciated, if you have any that you would like to share, feel free to email us at: info@gram-bioline.com



Produced by Gram Commercial a/s

Aage Grams Vej 1
DK-6500 Vojens
Denmark
+45 7320 1300
www.gram-bioline.com

Installation

Setting up

This part of the manual describes how to set up the cabinet.

This part of the manual describes how to adjust legs / casters on the cabinet.

Due to safety and operating reasons, the cabinet must not be used outdoors. The cabinet should be installed in a dry and sufficiently ventilated area. To ensure efficient operation, the cabinet should not be installed in direct sunlight or close to heat sources.

Cabinets equipped with legs should be levelled as shown in the illustration below.

NB. The cabinets optimal operating range is:

Cabinet	Minimum ambient operating temperature	Maximum ambient operating temperature
ER, RR with solid door: +10/+43 °C	+10 °C	+43 °C
ER, RR with glass door: +10/+38 °C	+10°C	+38 °C
RF: +10/+43 °C	+10 °C	+43 °C
EF: +10/+30 °C	+10 °C	+30 °C

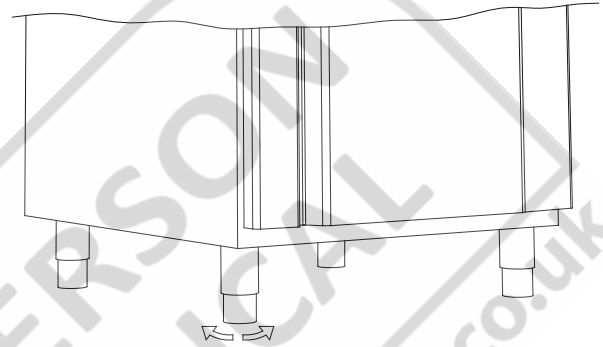

Avoid placement of the cabinet in an chlorine/acidic environment due to risk of corrosion.

For cabinets equipped with casters, the floor must be level to ensure stable positioning and safe use. When the cabinet is positioned, the 2 front casters should be locked.



The cabinet is shipped with a protective film that should be removed prior to use.

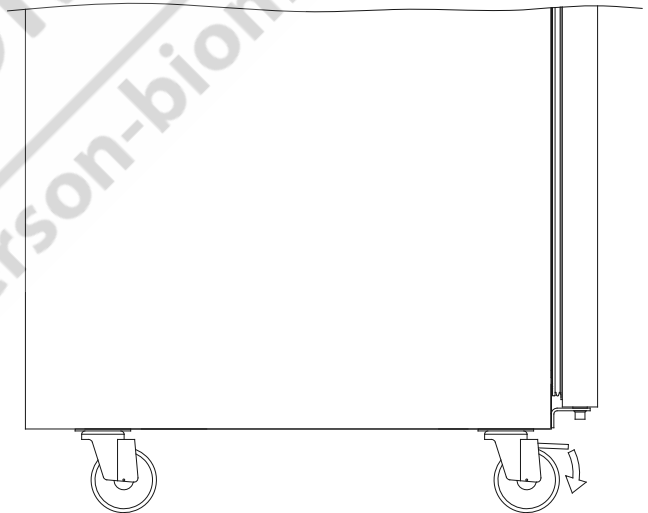
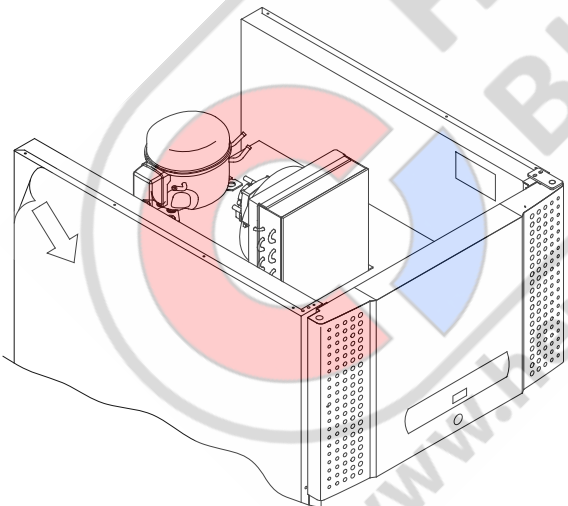

Clean the cabinet with a mild soap solution prior to use.





If the cabinet has been laying down (ex. during transport.) Then the cabinet must stand up-right for 24 hours prior to use, This enables oil in the compressor to run back into place.

Setting up

Cabinets with drawers and / or glass door must be secured to a stable vertical surface, ensuring that the cabinet can not tip over when the drawers are drawn to the outermost position, or the door is open. Brackets for securing is included.

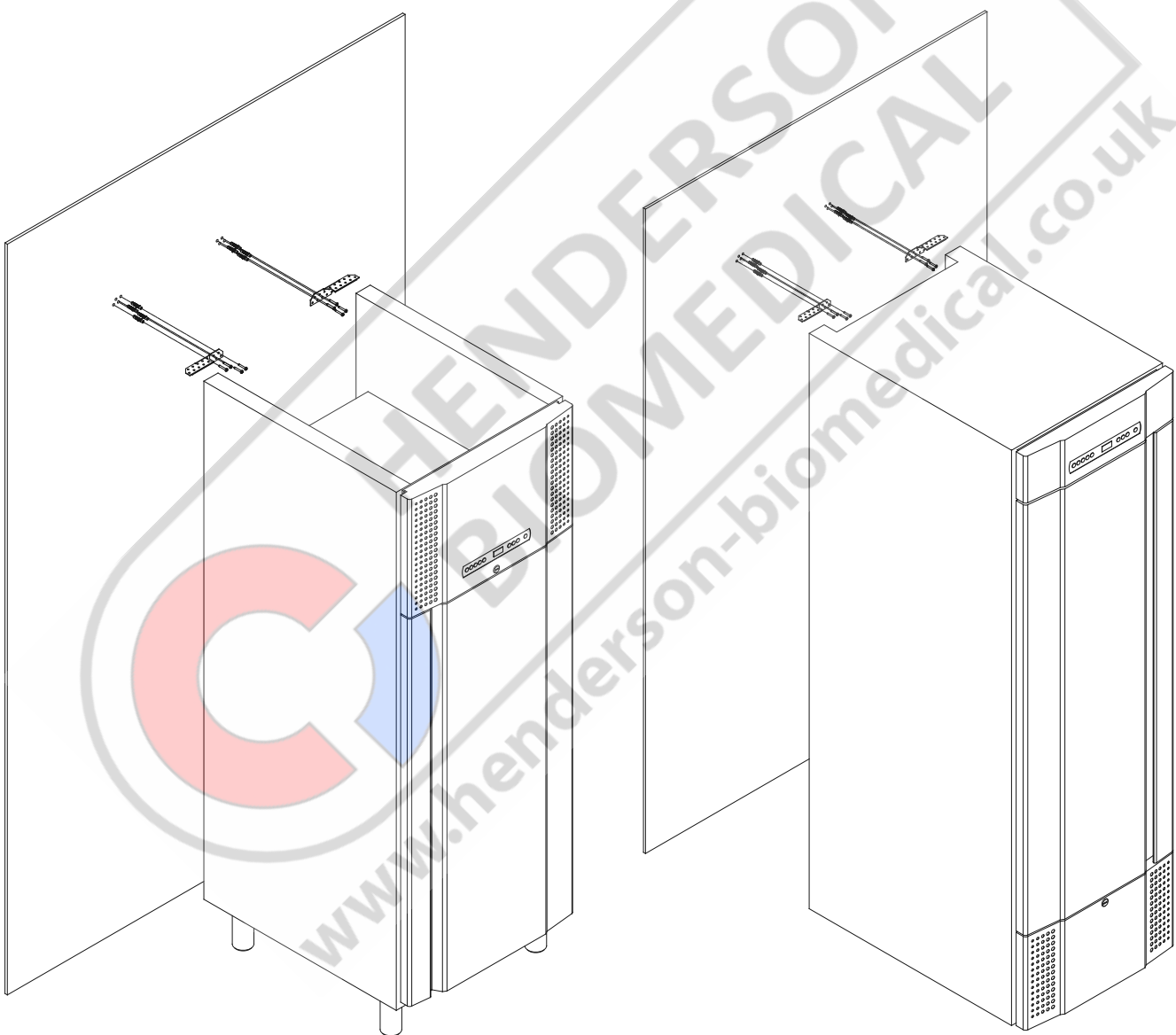
Find the instructions for the tilt bracket below.



 The tilt brackets must be fitted when installing the cabinet, ensuring that the users, surroundings and stored items are not damaged by the cabinet.

The cabinet must always be placed max. 75 mm from the wall while in use. It is optimal to install the cabinet as close to the wall as possible.



Do not cover the upper part of the cabinet if it has a top mounted compressor (applies to BioPlus 500, 600/660 and 1270/1400).

Max. 75mm

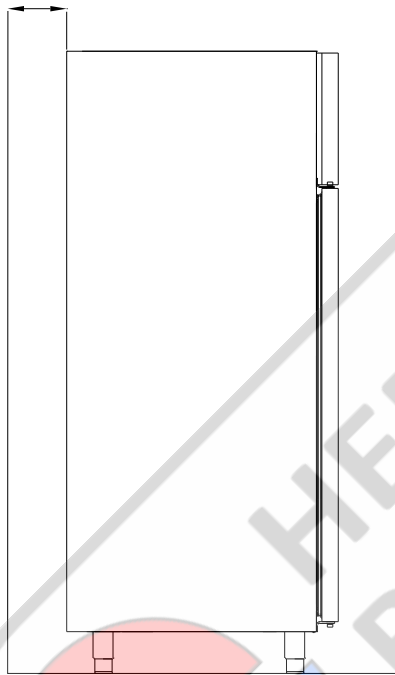

Do not cover the holes in the front panel of the cabinet.



Do not use electrical appliances inside the cabinet.



The cabinet is not suited for storing items that emit vapours, as they might corrode the cabinet and its components.



All items in the cabinet that are not encapsulated, or wrapped, should be covered to reduce the risk of corrosion of the cabinet and its components.



There must be at least a 30mm gap between cabinets.

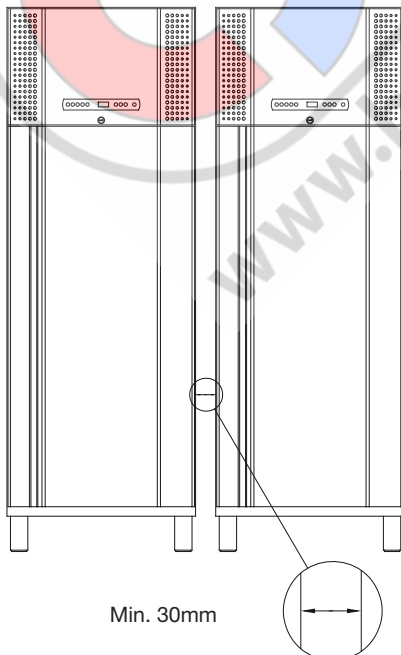

Min. 30mm

Voltage-free contact

This part of the manual covers the voltage-free contact.

The illustration below shows the three connectors for the relay (used ex. in connecting to CTS or other external monitoring systems). The three connections, are respectively. Common, NO and NC.

The moment when voltage is applied the controller draws the relay, this makes it possible for the controller to respond to both high and low alarms, door alarms and power failures. Temperature alarms and door alarms must be configured in the external alarm settings (EAL) before they will activate the voltage-free contact. Find instructions on setting external alarms in the Parameter settings section.

The wires that are connected in the connection block for the voltage-free contact, are secured in place by the press-fit plate that is pressed onto the block, thereby also preventing access to the electrical circuit.

Connection of the voltage-free contact should be done by a qualified installer.

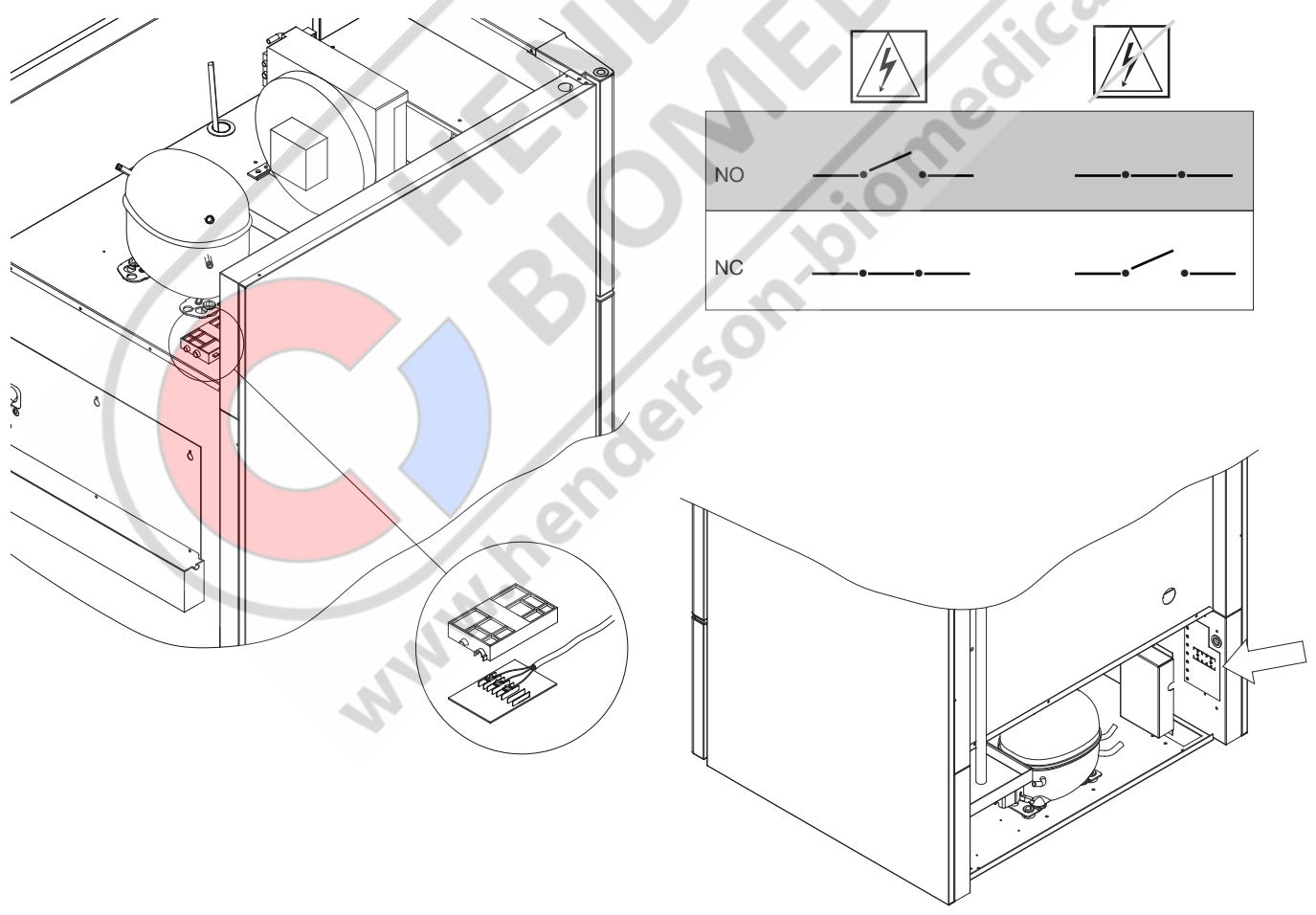

Mechanical low temperature protection

This part covers mechanical low temperature protection

The illustrations below depicts the locations of the low temperature protection on the different kinds of cabinets in the BioMidi/BioPlus range.

- Only applicable to models with mechanical low temperature protection -

Mechanical low temperature protection is an independent module that is connected to the compressor.

It measures the cabinets temperature and turns off the compressor (cut-off) if the temperature in the cabinet drops below the set value, ensuring that the cabinet does not become colder.

Please note that low temperature protection is set to between +2 and +2,5°C as factory settings.

Ensure that the scale is set at the correct temperature prior to installation.

The scale of the low temperature protection is turned counterclockwise to adjust the "cut-off" down, and clockwise to adjust the "cut-off" up.

Applicable to BioMidi 425, 625

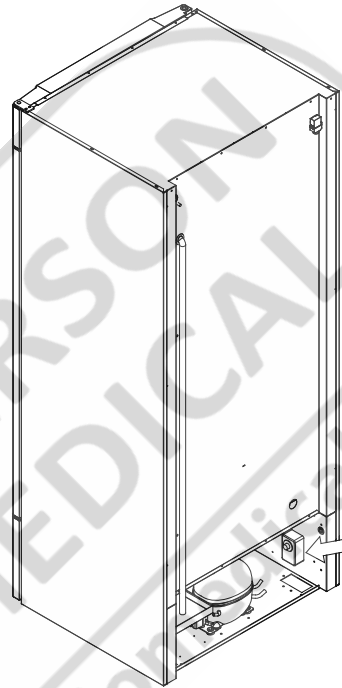

Applicable to BioPlus 500, 600/660 and 1270/1400

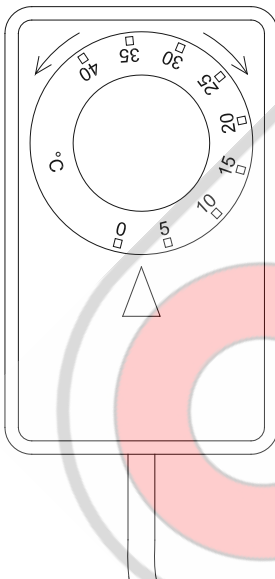
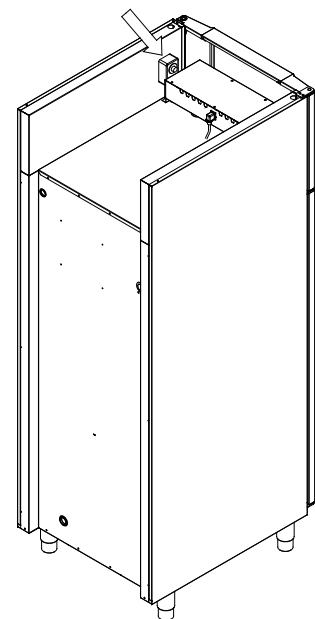

Example:

The compressor is turned off by the low temperature protection at 2.5 °C, the desired "cut-off" temperature is 1.5 °C.

Turn the scale on the low temperature protection counterclockwise until the desired value is set.

Connection to electricity

Read the following part thoroughly before connecting the cabinet. Contact an qualified electrician if in doubt.

Note that there are special regulations for products that are in accordance with EN 60079-15 zone 2.



The appliance has been manufactured in accordance with EN 60079-15: Electrical apparatus for explosive gas atmospheres - Part 15: Type of protection "n". Zone 2 is the applicable zone. If the appliance is to be installed in a zone 2 environment, specialist personnel should perform the installation, or be consulted beforehand, in order to ensure that the appliance is installed in compliance with the guidelines currently contained in the standard.



The cabinet is intended for connection to alternating current. The connection values for voltage (V) and frequency (Hz) are given on the nameplate in the engine room.



The power cord from the mains is plugged in the terminal box, in the engine room. The plug is then fixated in place by the hanger that is built into the terminal box. Please note that the hanger should be fitted tightly around the plug, as shown below.

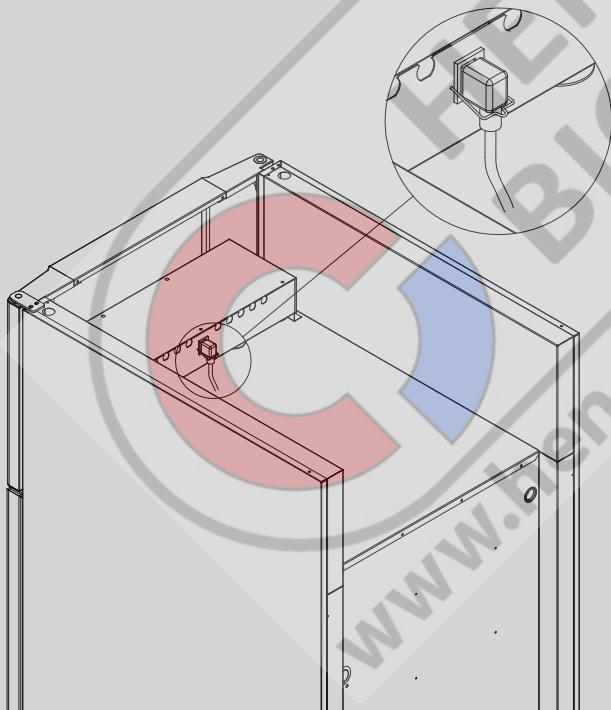

The appliance must be connected to the external power supply using a suitable device which mechanically prevents the plug and socket from being separated unintentionally. The connection must be labelled:

"DO NOT SEPARATE WHEN ENERGIZED"



IMPORTANT



Fuses and similar must never be removed or replaced while the appliance is connected to a power source.

The electrical terminal box must never be opened while the appliance is connected to a power source.

The compressor starting equipment must never be dismantled while the appliance is connected to a power source.

The halogen lighting must never be dismantled while the appliance is connected to a power source.

Whenever electrical components are dismantled or replaced, the appliance must be moved to an area in which there is no risk of ignition caused by the electrical components or gases contained in the appliance.

Never use the cabinet if the plug is damaged. The cabinet should be examined by a Gram Commercial service technician in such cases.

When setting up in an ordinary scenario that is not subject to regulations for Zone 2:

The appliance may be connected in accordance with applicable local heavy current regulations.

In both cases:

Use a three-wire plug, if the power outlet is intended for a three-wire plug, a the lead in green / yellow insulation should be connected to the ground terminal.

Power must be connected via a wall socket. The wall socket should be easily accessible.

All earthing requirements stipulated by the local electricity authorities must be observed. The cabinet plug and wall socket should then give correct earthing. If in doubt, contact your local supplier or authorized electrician.

In case of technical difficulties or breakdowns always contact an authorized service personnel. Never dismantle the terminal box or any other electrical component.

Start-up

The digital display

The digital display depicted below, shows the cabinets temperature and indicates if the cabinet is connected to a power source.

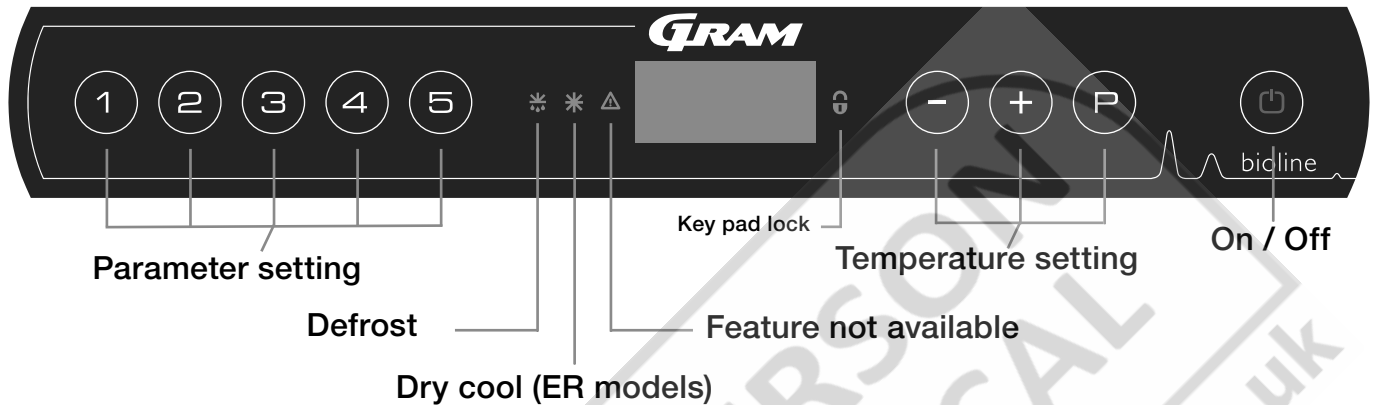

- Parameter setting - Gives access to the cabinets configureable parameters.
- Defrost - Defrost in progress
- Dry cool - Dry cool in progress (BioPlus ER-models)
- Key pad lock - Keypad is locked, no access to functions or menus
- Temperature setting - Setting of temperature setpoint and navigation in the menus
- On / Off - Turn the cabinet On or Off, and navigation in the menus

All-round introduction to navigating the menu

Beyond setting the temperature and on/off, (P), (+), (-) and (⏪) is used to navigate the menu and set the parameters of the cabinet.

The buttons have following functions in the menu:

- (P) - Open a menu step / confirm a set value in the parameter settings.
- (+) - Scroll upwards in a given menu / raise a given value in parameter settings (alarm setpoint for instance).
- (-) - Scroll downwards in a given menu / lower a given value in parameter settings.
- (⏪) - Go a menu step back

On / Off

Press the (⏪) button to turn the cabinet on. Press the (⏪) button for 6 seconds to turn the cabinet off. The software version of the cabinet will be shown when turning the cabinet on, followed by the software variant and a displaytest.

The cabinet is ready when the temperature is displayed. The cabinet will automatically start a defrost-cycle when turned on, and terminate it again after a system check..

⚠ Servicing:

Make sure the appliance is switched off at the socket before service is performed on electrical parts. It is not sufficient to switch off the cabinet on the START/STOP key, as current will persist in some electrical parts of the cabinet.

If fuses or similar are to be replaced, the appliance must be moved to a no-risk area.

Temperature setting

Temperature adjustments are done by holding the (P) button and pressing either (+) or (-). Confirm the settings by letting go of the buttons.

Walkthrough of menu

The menu below gives a quick overview of the parameter settings for the cabinet.

Please note: electric low temperature protection is not applicable to BioBlood cabinets

User menu

Menu Access (P)+(1)→	↓	→		
Local alarm settings	LAL	LHL	[° C]	Upper alarm limit. Code for activated alarm [A2]
		LLL	[° C]	Lower alarm limit. Code for activated alarm [A3]
		LHd	[Min.]	Delay of upper alarm limit
		LLd	[Min.]	Delay of lower alarm limit
		dA	On/off	Door alarm. Code for activated alarm [A1]. [1=on / 0=off]
		dAd	[Min.]	Delay of door alarm.
		bU	On/off	Acoustic signal for alarm codes [A1], [A2] and [A3]. [1=on / 0=off]
External alarm settings	EAL	EHL	[° C]	Upper alarm limit. Code for activated alarm [A4]
		ELL	[° C]	Lower alarm limit. Code for activated alarm [A5]
		EHd	[Min.]	Delay of upper alarm limit
		ELd	[Min.]	Delay of lower alarm limit
		dA	On/off	Door alarm. Code for activated alarm [A1]. [1=on / 0=off]
		dAd	[Min.]	Delay of external door alarm
		bU	On/off	Acoustic signal for external alarm codes [A1], [A4], [A5]. [1=on / 0=off]
Calibration of sensors	CAL	CA	[° K]	Calibration of A-sensor. Reference sensor for the refrigeration system
		CE	[° K]	Calibration of E-sensor. Reference sensor for the display and alarms
		CF	[° K]	Calibration of F-sensor. Reference sensor for the low temperature protection
Electric low temperature protection	FP	ACt	On/off	Activation/deactivation of low-temperature protection
		tES	On	Test of low-temperature protection
		SEt	[° C]	Setting of the cut-off temperature for the low-temperature protection
		PrE	[...]	Read out of the real-time temperature of the F-sensor
	ALL			Activation of escorted alarm limits. [FAS]= locked limits / [ESC] = follows setpoint
	dEF			Number of defrosts per 24 hours (4 is factory setting)
	dPS			Reference sensor for the display (A, E or F) (E is factory setting)

Other Shortcuts

Buttons:	Duration:	Function:
(P) + (⊕)	> 3 seconds	Start or stop a defrost.
(⊕) + (1)	> 6 seconds	Activating / deactivating the key pad lock.
(P)	-	Shows temperature setpoint value.
(+)	-	Shows the highest registered temperature spike (since the last clear and reset alarm history).
(-)	-	Shows the lowest registered temperature spike (since the last clear and reset alarm history).
(+) + (-)	> 3 seconds	Clear and reset alarm history
(P) + (1) + (⊖)	> 6 seconds	Reset of set parameters. Restores factory settings.
(P) + (1)	> 3 seconds	Access to user menu and alarm settings.

Error codes

The following table covers the different error codes that might occur.

Display code	Explanation
- 0 -	Door is open.
A1	Door alarm "dAd" from LAL and/or EAL has been activated.
A2	Local upper alarm LHL is or has been activated.
A3	Local lower alarm LLL is or has been activated.
A4	External upper alarm EHL is or has been activated.
A5	External lower alarm LLL is or has been activated.
F1	Error on the main cabinet sensor. The refrigeration system will use an emergency program to make the cabinet run. Temperature stability will be affected. Service is required.
F2	Error on the evaporator sensor. Service is required.
F3	Error on the 1. condenser sensor. Service is required.
F4	Error on the 2. condenser sensor. Service is required.
F5	Error on the extra sensor. Service is required.
F7	F7 indicates that the temperature of the condenser is too high. Turn off the cabinet and check that the condenser is not covered by undesirable items, and insure that the condenser (and possibly filter) is clean. Service is required if the problem is not alleviated.

Cancelling an acoustic alarm

Cancelling a door alarm: [A1] flashes in the display. Press **(P)** to cancel.

Cancelling a temperature alarm: [A2 and/or A3] Flashes in the display. Press **(P)** to cancel.

The display will continue to flash if the temperature is outside the alarm limits, and will continue until the temperature has recovered.

Reading the alarm history - Example [A2]

[A2] flashes in the display - This means that the temperature has exceeded the set value for the upper temperature limit, LHL.

Press **(P)** to cancel the [A2]. The display continues to flash, indicating that there is information in the alarm history. Press **(+)**,

Htt (High temperature time) is shown, press **(P)** to see for how long the temperature was above the set alarm limit. Press **(-)** to return to Htt.

Press **(+)** to reach Ht (Highest temperature). Press **(P)** to read the highest recorded temperature during Htt. Press **(-)** to return to Ht and press **(-)** again to leave the alarm history function.

The procedure for reading an [A3] alarm is identical, apart from entering the alarm history with the **(-)** button. When reading out temperatures below set limits, the parameters are Ltt and Lt.

A flashing display with no alarm codes indicates that the alarm codes have been cancelled, but the alarm history contains information.



Parameter settings

Dry cool

The following part covers activation / deactivation of the dry cool feature (only applicable to ER models).

dC - Setting the dry cool feature

- ↳ Press and hold (P) + (1) for more than 3 seconds
- ↳ Press (P) to choose "dC"
- ↳ Press (-) or (+) to choose between [H1= on] [H0=off]
- ↳ Press (P) to confirm
- ↳ Leave the user menu by pressing (⏏), press several times until the cabinet temperature is shown in the display.

Please note that the dry cool feature reduces that relative humidity in the cabinet, but does not control it.

Furthermore, please note that activation of the dry cool feature can cause greater fluctuations in the cabinet temperature during defrost.



HENDERSON
BIOMEDICAL
www.henderson-biomedical.co.uk

Local alarm settings

The following part covers the setting of upper and lower temperature alarm limits.

LHL - Setting the upper alarm limit [° C]

- ↳ Press and hold $\text{P} + \text{1}$ for more than 3 seconds
- ↳ Press + to proceed to "LAL" (Note: only applicable to ER models)
- ↳ Press P to select "LAL". "LHL" is now shown in the display
- ↳ Press P to select "LHL". The upper alarm limit is now shown in the display
- ↳ Press - or + to set the desired value for the upper alarm limit
- ↳ Press P to confirm the set value

- The upper alarm limit is now set, proceed to other parameters by pressing ⏏ , and then navigate by using + or - .

- ↳ Leave the user menu by pressing ⏏ several times until the cabinet temperature is shown in the display

LLL - Setting the lower alarm limit [° C]

- ↳ Press and hold $\text{P} + \text{1}$ for more than 3 seconds
- ↳ Press + to proceed to "LAL" (Note: only applicable to ER models)
- ↳ Press P to select "LAL". "LHL" is now shown in the display
- ↳ Press + to proceed to "LLL"
- ↳ Press P to select "LLL". The lower alarm limit is now shown in the display
- ↳ Press - or + to set the desired value for the lower alarm limit
- ↳ Press P to confirm the set value

- The lower alarm limit is now set, proceed to other parameters by pressing ⏏ , and then navigate by using + or - .

- ↳ Leave the user menu by pressing ⏏ several times until the cabinet temperature is shown in the display

Local alarm settings

The following part covers the setting of the delay for the local upper and lower temperature alarm limits.

LHd - Setting the delay of the local upper alarm limit [min.]

- ↳ Press and hold $\text{P} + \text{1}$ for more than 3 seconds
 - ↳ Press + to proceed to "LAL" (Note: only applicable to ER models)
 - ↳ Press P to select "LAL". "LHL" is now shown in the display
 - ↳ Press + several times until "LHd" is shown in the display
 - ↳ Press P to select "LHd". The delay of the upper alarm limit is now shown in the display
 - ↳ Press - or + to set the desired value for the delay of the upper alarm limit
 - ↳ Press P to confirm the set value
- The delay of the upper alarm limit is now set, proceed to other parameters by pressing ⏏ , and then navigate by using + or - .
- ↳ Leave the user menu by pressing ⏏ several times until the cabinet temperature is shown in the display

LLd - Setting the delay of the local lower alarm limit [min.]

- ↳ Press and hold $\text{P} + \text{1}$ for more than 3 seconds
 - ↳ Press + to proceed to "LAL" (Note: only applicable to ER models)
 - ↳ Press P to select "LAL". "LHL" is now shown in the display
 - ↳ Press + several times until "LLd" is shown in the display
 - ↳ Press P to select "LLd". The delay of the lower alarm limit is now shown in the display
 - ↳ Press - or + to set the desired value for the delay of the lower alarm limit
 - ↳ Press P to confirm the set value
- The delay of the lower alarm limit is now set, proceed to other parameters by pressing ⏏ , and then navigate by using + or - .
- ↳ Leave the user menu by pressing ⏏ several times until the cabinet temperature is shown in the display

On / Off local door alarm

The following part covers the setting of the door alarm and the delay of the door alarm.

Delay for local door alarm

dA - Activate / deactivate of local door alarm

- ↳ Press and hold $\text{P} + \text{1}$ for more than 3 seconds
 - ↳ Press + to proceed to "LAL" (Note: only applicable to ER models)
 - ↳ Press P to select "LAL". "LHL" is now shown in the display
 - ↳ Press + several times until "dA" is shown in the display
 - ↳ Press P to select "dA".
 - ↳ Press - or + to activate / deactivate the local door alarm [1 = activated / 0 = deactivated]
 - ↳ Press P to confirm the set value
- The local door alarm is now configured, proceed to other parameters by pressing ⏏ , and then navigate by using + or - .
- ↳ Leave the user menu by pressing ⏏ several times until the cabinet temperature is shown in the display

dAd - Setting the delay of the local door alarm [min.]

- ↳ Press and hold $\text{P} + \text{1}$ for more than 3 seconds
 - ↳ Press + to proceed to "LAL" (Note: only applicable to ER models)
 - ↳ Press P to select "LAL". "LHL" is now shown in the display
 - ↳ Press + several times until "dAd" is shown in the display
 - ↳ Press P to select "dAd". The delay of the local door alarm is now shown in the display
 - ↳ Press - or + to set the desired value for the delay of the local door alarm
 - ↳ Press P to confirm the set value
- The delay of the local door alarm is now configured, proceed to other parameters by pressing ⏏ , and then navigate by using + or - .
- ↳ Leave the user menu by pressing ⏏ several times until the cabinet temperature is shown in the display

Local alarm settings

The following part covers the setting of the acoustic local alarms.

bU - Activation / deactivation of the acoustic local alarms

- ↳ Press and hold P + 1 for more than 3 seconds
 - ↳ Press + to proceed to "LAL" (Note: only applicable to ER models)
 - ↳ Press P to select "LAL". "LHL" is now shown in the display
 - ↳ Press + several times until "bU" is shown in the display
 - ↳ Press P to select "bU".
 - ↳ Press - or + to activate / deactivate the local acoustic alarms [1 = activated / 0 = deactivated]
 - ↳ Press P to confirm the set value
- The local acoustic alarms is configured, proceed to other parameters by pressing ⊕ , and then navigate by using + or - .
- ↳ Leave the user menu by pressing ⊕ several times until the cabinet temperature is shown in the display



Important!

In order to assure the safety of the stored items, the local alarms should be supported by external alarms. This can be done by utilizing the possibility of external alarms via the voltage-free contact.

Please find instructions for connecting the "voltage-free contact" in "Installation"

External alarm settings

The following part covers the setting of upper and lower external temperature alarm limits.

EHL - Setting the external upper alarm limit [° C]

- ↳ Press and hold $\text{P} + \text{1}$ for more than 3 seconds
- ↳ Press + several times until "EAL" is shown in the display
- ↳ Press P to select "EAL". "EHL" is now shown in the display
- ↳ Press P to select "EHL". The external upper alarm limit is now shown in the display
- ↳ Press - or + to set the desired value for the external upper alarm limit
- ↳ Press P to confirm the set value

- The external upper alarm limit is now set, proceed to other parameters by pressing ⏏ , and then navigate by using + or - .

- ↳ Leave the user menu by pressing ⏏ several times until the cabinet temperature is shown in the display

ELL - Setting the external lower alarm limit [° C]

- ↳ Press and hold $\text{P} + \text{1}$ for more than 3 seconds
- ↳ Press + several times until "EAL" is shown in the display
- ↳ Press P to select "EAL". "EHL" is now shown in the display
- ↳ Press + to proceed to "ELL"
- ↳ Press P to select "ELL". The external lower alarm limit is now shown in the display
- ↳ Press - or + to set the desired value for the external lower alarm limit
- ↳ Press P to confirm the set value

- The external lower alarm limit is now set, proceed to other parameters by pressing ⏏ , and then navigate by using + or - .

- ↳ Leave the user menu by pressing ⏏ several times until the cabinet temperature is shown in the display

External alarm settings

The following parts covers the setting of the delay of the external upper and lower alarms.

EHD - Setting the delay of the external upper alarm limit [min.]

- ↳ Press and hold $\text{P} + \text{1}$ for more than 3 seconds
 - ↳ Press + to proceed to "EAL"
 - ↳ Press P to select "EAL". "EHL" is now shown in the display
 - ↳ Press + several times until "EHD" is shown in the display
 - ↳ Press P to select "EHD". The external delay of the upper alarm limit is now shown in the display
 - ↳ Press - or + to set the desired value for the external delay of the upper alarm limit
 - ↳ Press P to confirm the set value
- The delay of the external upper alarm limit is now set, proceed to other parameters by pressing ⏏ , and then navigate by using + or -
- ↳ Leave the user menu by pressing ⏏ several times until the cabinet temperature is shown in the display

ELd - Setting the delay of the external lower alarm limit [min.]

- ↳ Press and hold $\text{P} + \text{1}$ for more than 3 seconds
 - ↳ Press + to proceed to "EAL"
 - ↳ Press P to select "EAL". "EHL" is now shown in the display
 - ↳ Press + several times until "ELd" is shown in the display
 - ↳ Press P to select "ELd". The delay of the external lower alarm limit is now shown in the display
 - ↳ Press - or + to set the desired value for the delay of the lower alarm limit
 - ↳ Press P to confirm the set value
- The delay of the external lower alarm limit is now set, proceed to other parameters by pressing ⏏ , and then navigate by using + or -
- ↳ Leave the user menu by pressing ⏏ several times until the cabinet temperature is shown in the display

On / Off external door alarm

The following parts covers the setting and delay, of the external door alarm.

Delay for external door alarm

dA - Activation / deactivation of external door alarm

- ↳ Press and hold **(P)** + **(1)** for more than 3 seconds
 - ↳ Press **(+)** to proceed to "EAL"
 - ↳ Press **(P)** to select "EAL". "EHL" is now shown in the display
 - ↳ Press **(+)** several times until "dA" is shown in the display
 - ↳ Press **(P)** to select "dA"
 - ↳ Press **(-)** or **(+)** to activate / deactivate the external door alarm [1 = activated / 0 = deactivated]
 - ↳ Press **(P)** to confirm the set value
- The external door alarm is now configured, proceed to other parameters by pressing **(M)**, and then navigate by using **(+)** or **(-)**.
- ↳ Leave the user menu by pressing **(M)** several times until the cabinet temperature is shown in the display

dAd - Setting the delay of the external door alarm [min.]

- ↳ Press and hold **(P)** + **(1)** for more than 3 seconds
 - ↳ Press **(+)** to proceed to "EAL"
 - ↳ Press **(P)** to select "EAL". "EHL" is now shown in the display
 - ↳ Press **(+)** several times until "dAd" is shown in the display
 - ↳ Press **(P)** to select "dAd". The delay of the external door alarm is now shown in the display
 - ↳ Press **(-)** or **(+)** to set the desired value for the delay of the external door alarm
 - ↳ Press **(P)** to confirm the set value
- The delay of the external door alarm is now configured, proceed to other parameters by pressing **(M)**, and then navigate by using **(+)** or **(-)**.
- ↳ Leave the user menu by pressing **(M)** several times until the cabinet temperature is shown in the display

External alarm settings

The following part covers the setting of the acoustic external alarms.

bU - Activation / deactivation of the acoustic external alarms

- ↳ Press and hold P + 1 for more than 3 seconds
 - ↳ Press + to proceed to "EAL"
 - ↳ Press P to select "EAL". "EHL" is now shown in the display
 - ↳ Press + several times until "bU" is shown in the display
 - ↳ Press P to select "bU"
 - ↳ Press - or + to activate / deactivate the external acoustic alarms [1 = activated / 0 = deactivated]
 - ↳ Press P to confirm the set value
- The external acoustic alarms is configured, proceed to other parameters by pressing P , and then navigate by using + or - .
- ↳ Leave the user menu by pressing P several times until the cabinet temperature is shown in the display

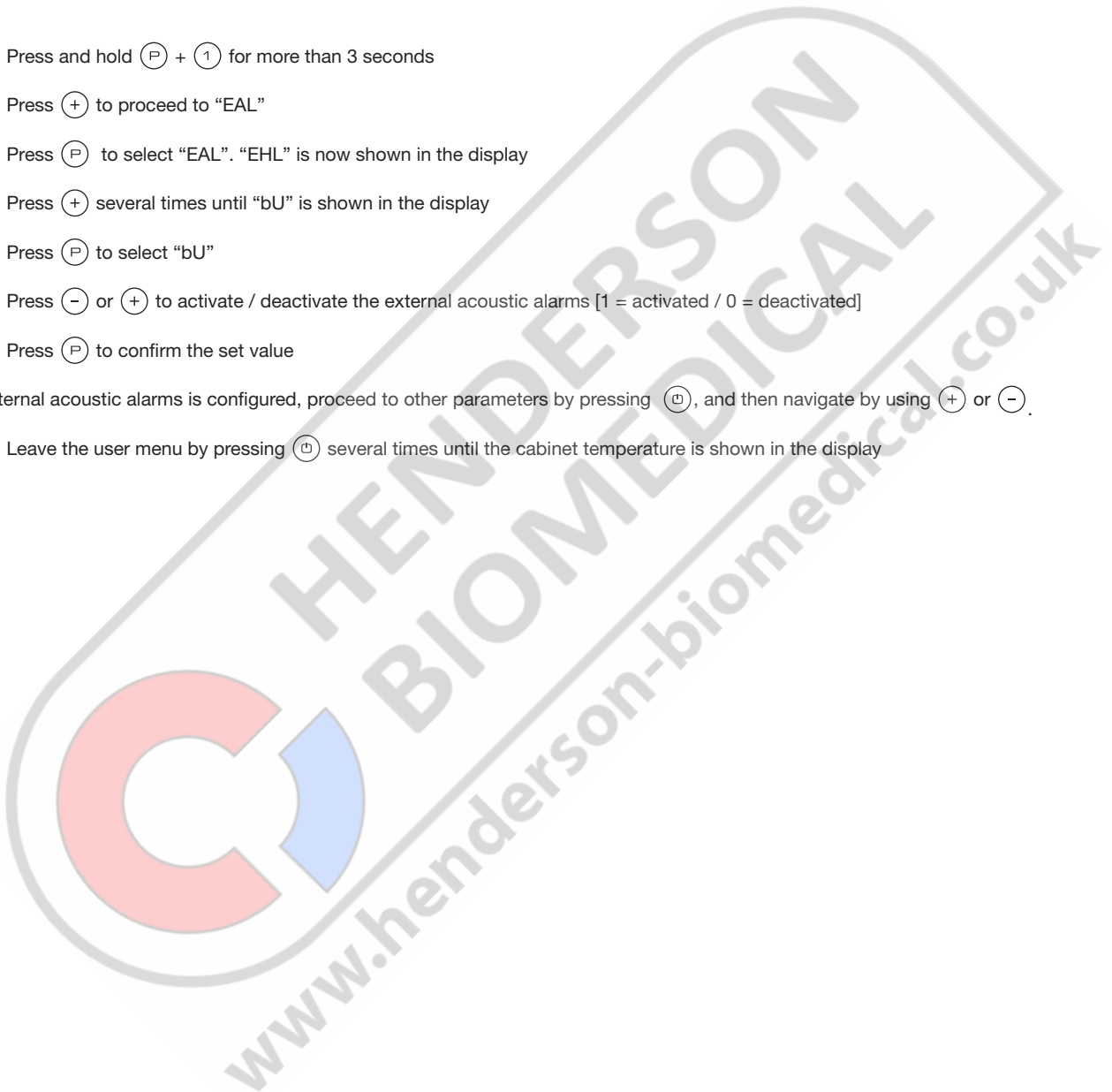

Sensor calibration

The following part covers the calibration of the A- and E-sensor.

The temperature sensors connected to MPC controller can be calibrated independently of each other under the parameter cAL.

Calibration is used in cases where there are deviations in the cabinets actual operation compared to the display and / or control measurements by independent temperature monitoring.

The cabinet is equipped with a sensor (A-sensor) and an extra sensor (E-sensor).

The A-sensor is used to manage the cabinets refrigeration system and is fixated in a given position in the cabinet, not in storage space. The location of the A sensor must not be altered.

The E-sensor is placed in the cabinet storage space and can be moved around in the cabinet to get the desired reference point for temperature. The E-sensor is the default display sensor and reference for the alarms. The E-sensor has no effect on control of the refrigeration system.

The A-sensor is calibrated if the actual temperature in the cabinet does not match the setpoint, despite taking the hysteresis into consideration. Calibration of A sensor is named "cA".

The E-sensor is calibrated if the actual temperature in the cabinets display, provided that the display sensor for reference is the E-sensor, does not match the independent temperature monitoring used for control. Calibration of E-sensor is named "cE"

Practical example of calibration:

Example 1 - The temperature in the cabinet is operating colder than the actual setpoint.

With a setpoint of +4 °C, the actual temperature inside the cabinet is between +2 and +4 °C. The desired temperature range is between +3 and +5 °C. This means that "cA", in this case, should be -1,0K, so that the refrigeration system stops 1,0K before and starts 1,0K later than the setpoint normally otherwise would dictate.

Example 2 - The temperature in the cabinet is operating warmer than the actual setpoint.

With a setpoint of +4 °C, the actual temperature inside the cabinet is between +4 and +6 °C. The desired temperature range is between +3 and +5 °C. This means that "cA", in this case, should be 1,0K, so that the refrigeration system stops 1,0K later and starts 1,0K earlier than the setpoint normally otherwise would dictate.

Calibration of the A-sensor

- ↳ Press and hold (P) + (1) for more than 3 seconds
- ↳ Press (+) several times until "cAL" is shown in the display
- ↳ Press (P) to select "cAL". "cA" is shown in the display
- ↳ Press (P) to select "cA"
- ↳ Press (-) or (+) to calibrate the A-sensor
- ↳ Press (P) to confirm the set value

-The A-sensor is now calibrated, proceed to other parameters by pressing (⏪), and then navigate by using (+) or (-)

- ↳ Leave the user menu by pressing (⏩) several times until the cabinet temperature is shown in the display

Calibration of the E-sensor

- ↳ Press and hold (P) + (1) for more than 3 seconds
- ↳ Press (+) several times until "cAL" is shown in the display
- ↳ Press (P) to select "cAL". "cA" is shown in the display
- ↳ Press (+) until "cE" is shown in the display
- ↳ Press (P) to select "cE"
- ↳ Press (-) or (+) to calibrate the E-sensor
- ↳ Press (P) to confirm the set value

- The E-sensor is now calibrated, proceed to other parameters by pressing (⏪), and then navigate by using (+) or (-)

- ↳ Leave the user menu by pressing (⏩) several times until the cabinet temperature is shown in the display

Escorted / set alarm limits

The following part covers the setting of escorted or set alarm limits.

ALL - Setting of escorted / set alarm limits

- ↳ Press and hold (P) + (1) for more than 3 seconds
- ↳ Press (+) several times until "ALL" is shown in the display
- ↳ Press (P) to select "ALL"
- ↳ Press (-) or (+) to select set or escorted alarm limits
- ↳ Press (P) to confirm the set value
- ↳ Leave the user menu by pressing (⏏) several times until the cabinet temperature is shown in the display

Defrosts / 24 hours

The following part covers the setting of the amount of defrosts per 24 hours.

dEF- Number of defrosts

- ↳ Press and hold (P) + (1) for more than 3 seconds
- ↳ Press (+) several times until "dEF" is shown in the display
- ↳ Press (P) to select "dEF"
- ↳ Press (-) or (+) to set the desired amount of defrosts per 24 hours (factory setting is 4)
- ↳ Press (P) to confirm the set value
- ↳ Leave the user menu by pressing (⏏) several times until the cabinet temperature is shown in the display



Please note: It is very important that defrosts should not be set to 0 for a prolonged period of time, as this will reduce the cooling capacity of the cabinet.

"Set alarm" is fixed limits working independently from the setpoint. The alarm limits will remain the selected values regardless of the setpoint being altered.

"Escorted alarm" is fixed limits locked to the setpoint. The alarm limits will change according to the altered setpoint.

Display sensor

The following part covers the setting of which sensor to be shown in the display.

dPS - Selection of reference sensor for the display

- ↳ Press and hold (P) + (1) for more than 3 seconds
- ↳ Press (+) several times until "dPS" is shown in the display
- ↳ Press (P) to select "dPS"
- ↳ Press (-) or (+) to select either the A- or E-sensor
- ↳ Press (P) to confirm the set value
- ↳ Leave the user menu by pressing (⏻) several times until the cabinet temperature is shown in the display

Please note that dPS only changes the reference sensor for the display, and not the reference sensor for the alarms.

Furthermore please note that the reference sensor for the refrigeration system is the A-sensor, this can not be altered.

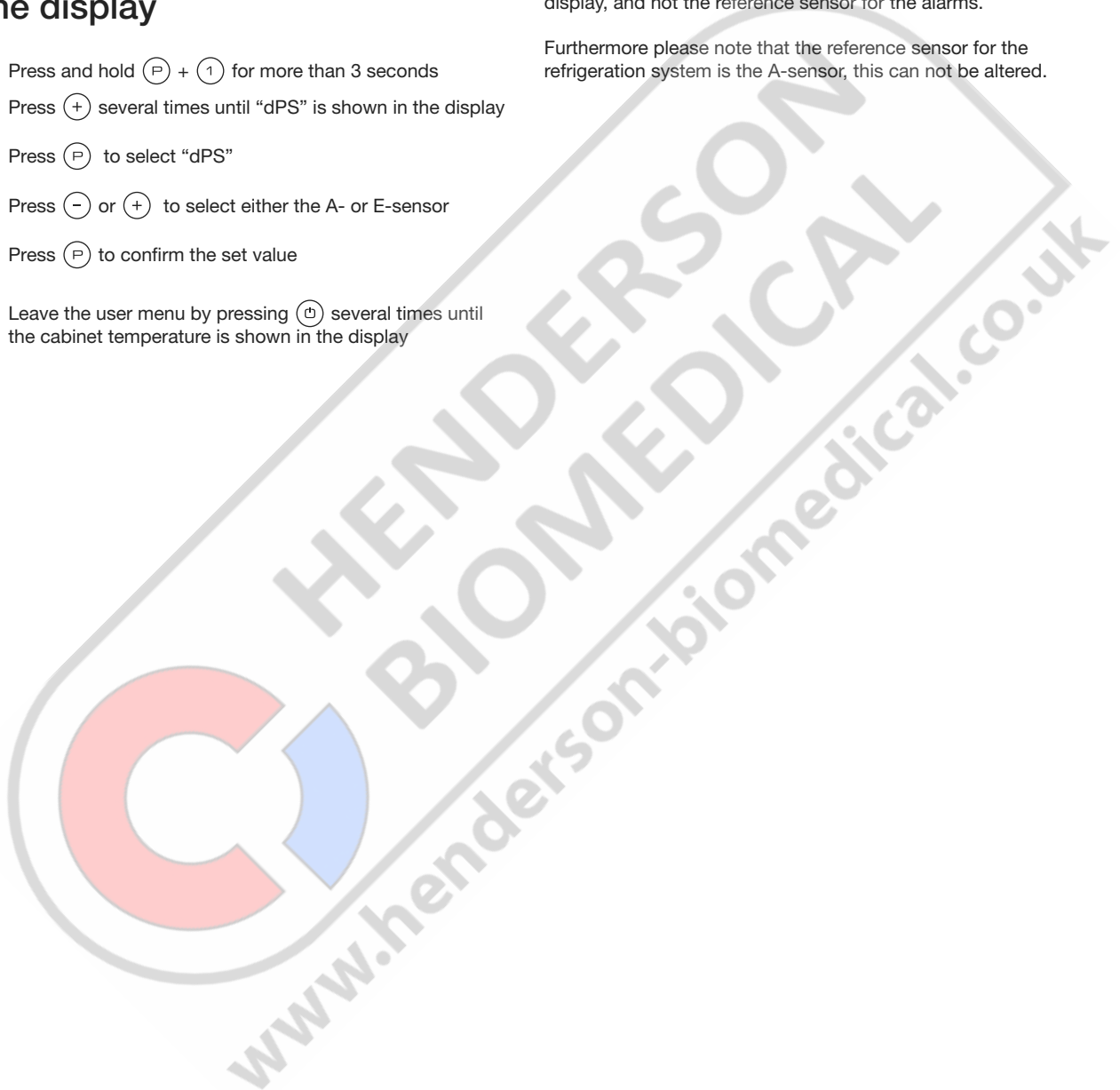

Electric low temperature protection

Electric low temperature protection is not available for BioBlood.

FP - Activation / deactivation of low temperature protection

- ↳ Press and hold (P) + (1) for more than 3 seconds
- ↳ Press (+) several times until "FP" is shown in the display
- ↳ Press (P) to select "FP". "Act" is now shown in the display
- ↳ Press (P) to select "Act"
- ↳ Press (-) or (+) to activate / deactivate [1 = activated / 0 = deactivated]
- ↳ Press (P) to confirm the set value
- ↳ Leave the user menu by pressing (⏏) several times until the cabinet temperature is shown in the display

FP - Test of low temperature protection

- ↳ Press and hold (P) + (1) for more than 3 seconds
- ↳ Press (+) several times until "FP" is shown in the display
- ↳ Press (P) to select "FP". "Act" is now shown in the display
- ↳ Press (+) to progress to "tES"
- ↳ Press (P) to select "tES" - test will then be performed
- ↳ Leave the user menu by pressing (⏏) several times until the cabinet temperature is shown in the display



HENDERSON
BIOMEDICAL
www.henderson-biomedical.co.uk

Electric low temperature protection is not available for BioBlood.



FP - Setpoint of low temperature protection

FP - Temperature of low temperature protection sensor

- ↳ Press and hold (P) + (1) for more than 3 seconds
- ↳ Press (+) several times until "FP" is shown in the display
- ↳ Press (P) to select "FP". "Act" is now shown in the display
- ↳ Press (+) several times until "SET" is shown in the display
- ↳ Press (P) to select "SET"
- ↳ Press (-) or (+) to select the setpoint temperature for the low temperature protection
- ↳ Press (P) to confirm the set value
- ↳ Leave the user menu by pressing (E) several times until the cabinet temperature is shown in the display

- ↳ Press and hold (P) + (1) for more than 3 seconds
- ↳ Press (+) several times until "FP" is shown in the display
- ↳ Press (P) to select "FP". "Act" is now shown in the display
- ↳ Press (P) to select "Pre"
- ↳ Press (P) to show the low temperature protection sensor temperature
- ↳ Leave the user menu by pressing (E) several times until the cabinet temperature is shown in the display

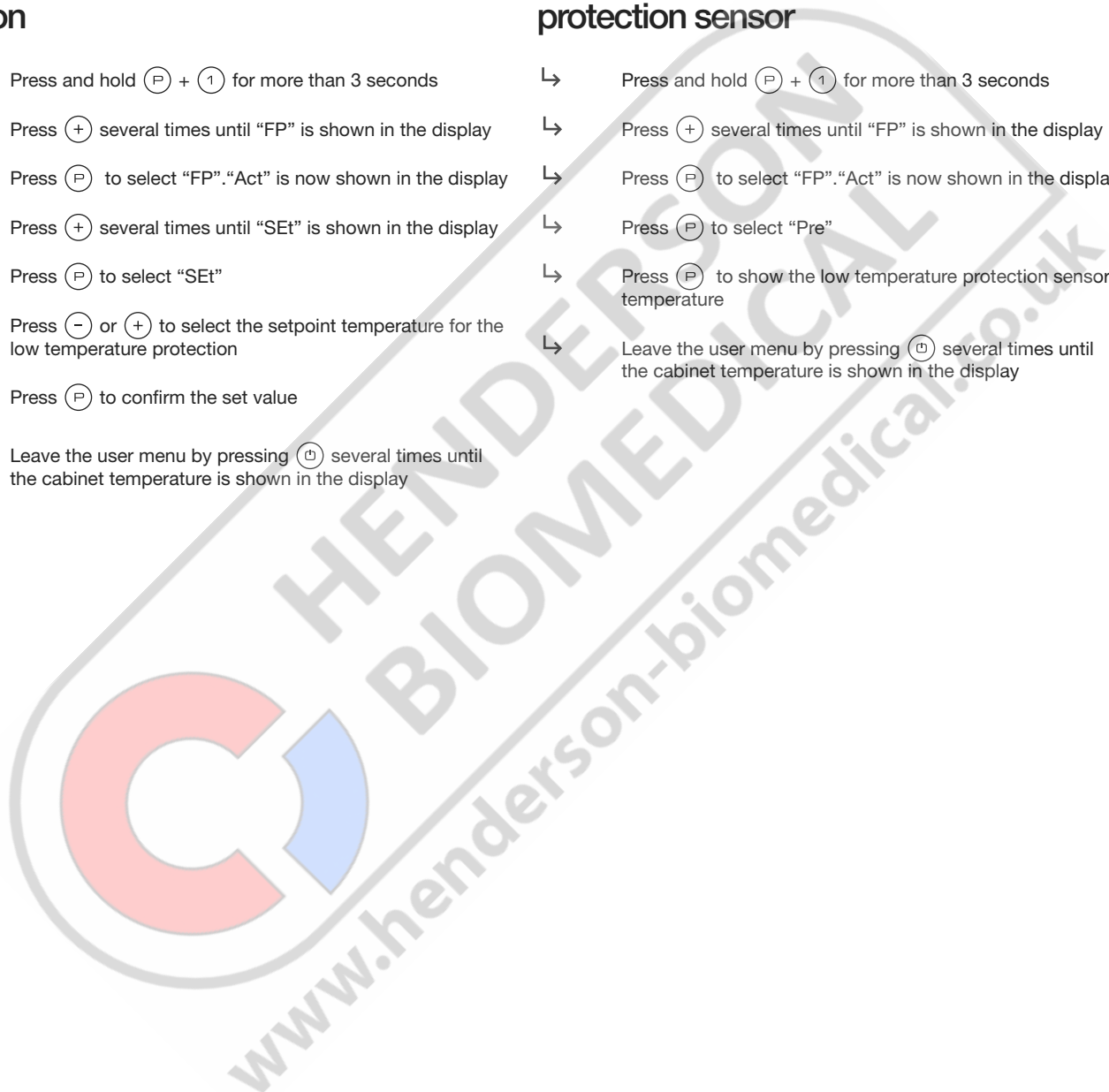

Reversing of door

The following part covers the process of reversing a door on a cabinet with a top mounted compressor

1. Disconnect the cabinet at the wall socket. Remove the hinge in position "A". You are now able to remove the front panel (remember to disconnect cables to the display and lighting).
2. Now remove the hinge in position B, lift the door out of the bottom hinge in position "C". Remove the foot pedal in position "D", and mount the new foot pedal in position "H".
3. Move the hinge from position "B" to position "G", the nylon washer is attached.
4. Rotate the door 180 ° relative to the original installation. Put the self closing in the neutral position (see Fig. 1). Check that the spring is in correct working order before further assembly.
5. Move the hinge from position "C" to "F". Set the door in the hinge at position "G". Adjust the door and finally fasten the hinge in position "F".
6. Drop the front panel into the hinge in position "F". Attach the hinge from position "A" to position "E".
7. Re-connect the cables for the front panel and close the panel. Reconnect the power at the wall socket.

The following part covers the process of reversing a door on a cabinet with a bottom mounted compressor

1. Disconnect the cabinet at the wall socket. Remove the hinge in position "A". Remove the top front panel (remember to disconnect cables to the display and lighting). Remove the bottom front panel by pulling it outwards.
2. Now remove the hinge in position "B", lift the door out of the bottom hinge in position "C". Mount the hinge from position "B" in position "E", the nylon washer attached.
3. Rotate the door 180 ° relative to the original installation. Put the self closing in the neutral position (see Fig. 1). Check that the spring is in correct working order before further assembly.
4. Move the hinge from position "C" to position "D".
5. Set the door in the hinge at position "E". Adjust the door and finally fasten the hinge in position "D". Move closing mechanism for the top front panel from position "I" to position "J".
6. Drop the top front panel into the hinge in position "D". Re-connect the cables in the front panel and the upper hinge of position "A". Install the bottom front panel. Reconnect the power at the wall socket.



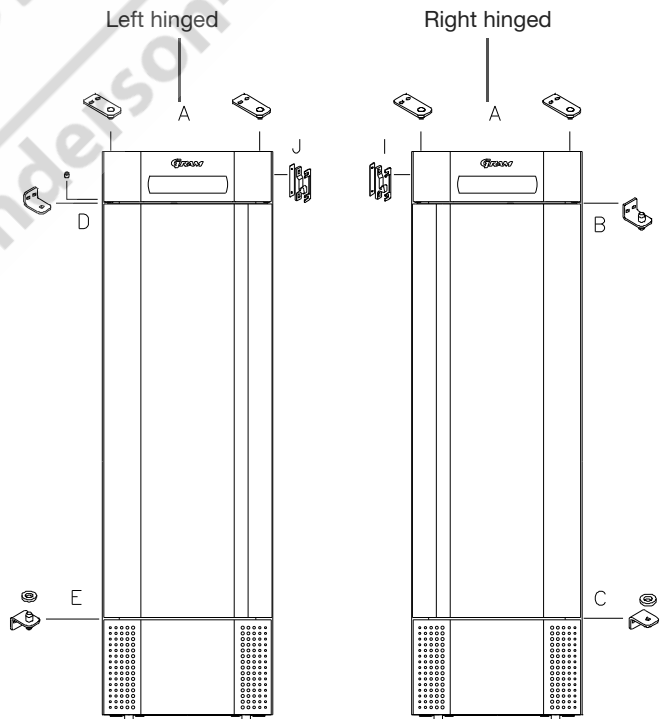
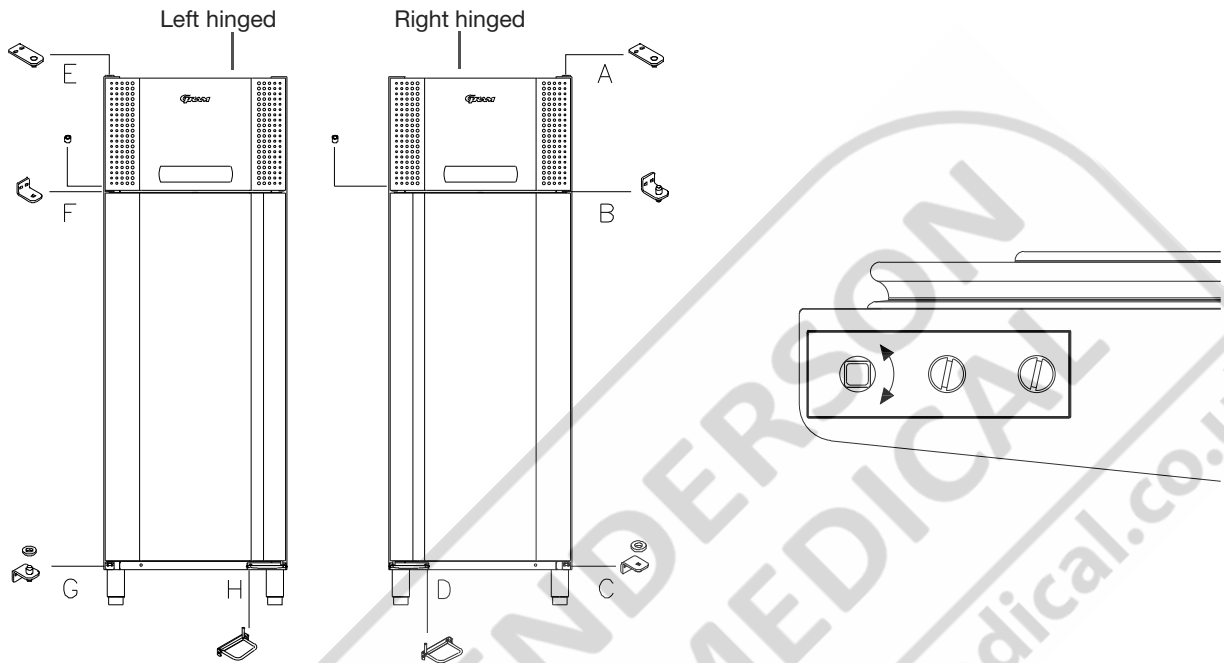

HENDERSON
 BIOMEDICAL
 www.henderson-biomedical.co.uk

Ordinary use

The following part shows how items should be placed and stored in the cabinet.

Keep the marked areas in the cabinet (shown on this page) clear of all items, thereby ensuring adequate air circulation, and therein cooling.

Do not place items beneath the lowest shelf bracket.

All products to be stored, that are not wrapped or packed, must be covered in order to avoid unnecessary corrosion of the inner parts of the cabinet.



Items placed on the bottom of the cabinet will cause the air circulation to be impeded, which reduces the cabinets performance.

The items should be evenly distributed in the cabinet, with minimum layer-thickness / maximum surface. And at the same time, the air should be able to circulate freely between the items.

The illustration on the right shows the maximum load height of the cabinet.

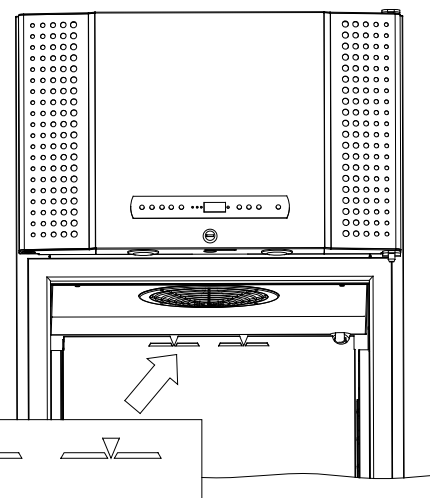
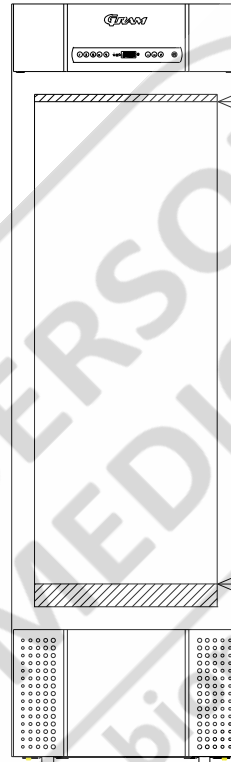

Cleaning

Inadequate cleaning can lead to the cabinet not functioning properly or at all.

Always disconnect the cabinet before cleaning.

The cabinet should be cleaned internally with a mild soap solution (max. 85 °C) at suitable intervals and checked thoroughly before it is put into operation again.

For the external maintenance – use stainless steel polish.

The compressor compartment and in particular the condenser must be kept free from dust and dirt. This is best done with a vacuum cleaner and a brush.

The air filters on the condenser and the front panel should be removed and cleaned with warm water (max. 50°C).

The re-evaporation tray should be emptied and cleaned at least once a year.

Do not flush compressor compartment and evaporator with water as this may cause short-circuits in the electrical system.

Cleansing agents containing chlorine or compounds of chlorine as well as other corrosive agents, may not be used, as they might cause corrosion to the stainless panels of the cabinet and the evaporator system.

The location of the condensers for both bottom- and top-mounted cabinets is illustrated below.

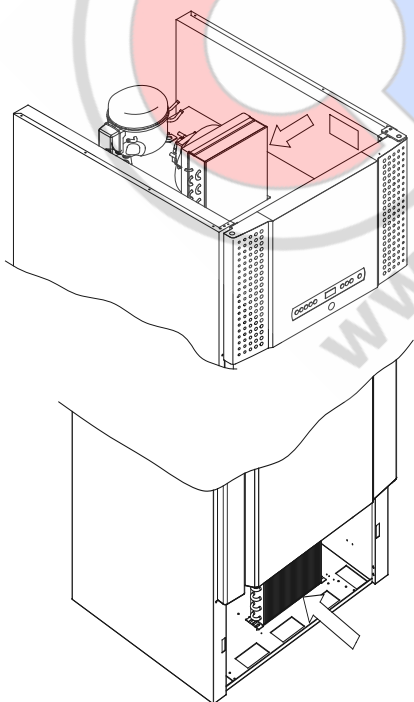

Door gasket

The following part covers the importance of a properly functioning door gasket.

Door gaskets are an important part of a cabinet, door gaskets with impaired functionality reduces a cabinets seal with the door. Impaired seals can lead to increased humidity, iced evaporator (and thus reduced cooling capacity), and in some cases, decreased lifetime expectancy of the cabinet.

It is therefore very important to be aware of the door gaskets condition. Regular inspection is recommended.

The door gasket should be cleaned regularly with a mild soap solution.

If a gasket is to be replaced, please contact your local Gram BioLine distributor.

The illustration below shows the location of the seal on a BioPlus 660

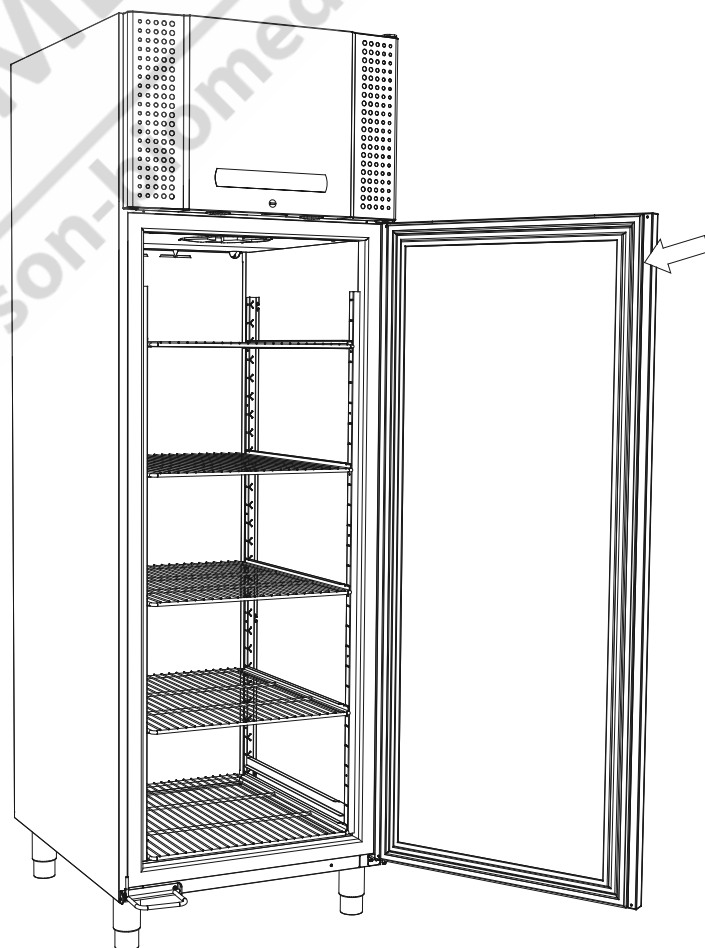

General info

Responsibility

Read the following carefully, for information on technical safety and responsibility on Gram Commercial products.

Is the cabinet being used for purposes other than its intended use, or use of the cabinet is not in accordance with guidelines specified in the user manual, the user bears full responsibility for any consequences thereof.

Defective parts must be replaced with original parts from Gram Commercial. Gram Commercial can only guarantee functional and safety requirements on the cabinets, if above mentioned is adhered to.



The cabinets refrigeration components should at least once a year, be checked by Gram Commercial technician or a similar professional.

Service

The refrigerating system and the hermetically sealed compressor require no maintenance. However, the condenser and air filter requires regular cleaning.

If refrigeration fails, first look to see whether the cabinet has been unintentionally switched off, or whether a fuse has blown.

If the cause of failure cannot be found, contact your supplier quoting TYPE, PART NO and SE. NO of the cabinet. This information can be found on the nameplate.

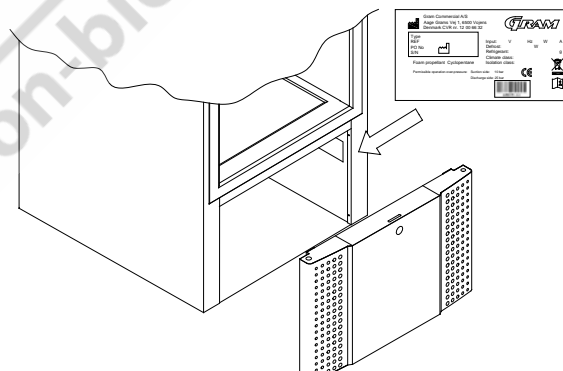
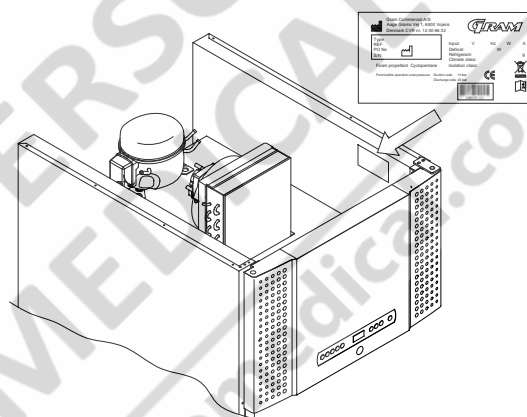

The cabinet has to be disconnected at the mains if service is to be done on electrical components of the cabinet.

It is not sufficient to switch the cabinet off on the front panel, due to the fact that there is still a possibility that there is current in some of the components of the cabinet.



Contact Gram customer service or qualified personnel if the bulb(s) in the two spots above the door needs replacing

Defrost water

The cabinet creates defrost water, that is directed out into a re-evaporation tray at the back of the cabinet.

BioPlus (500, 600/660, 1270/1400):

Defrost water is led through a tube in insulation to a re-evaporation tray at the back of the cabinet.

BioMidi 425.625:

Defrost water is led through a tube in the insulation to a re-evaporation tray in the compressor room in the cabinet.



It is recommended that the re-evaporation tray is cleaned at least once a year. This shall only be done while the cabinet is turned off.

Be careful not to damage the defrost water tube and heating element (located in the tray) when cleaning.

Below are the re-evaporation trays for a BioMidi 625 and BioPlus 600 shown

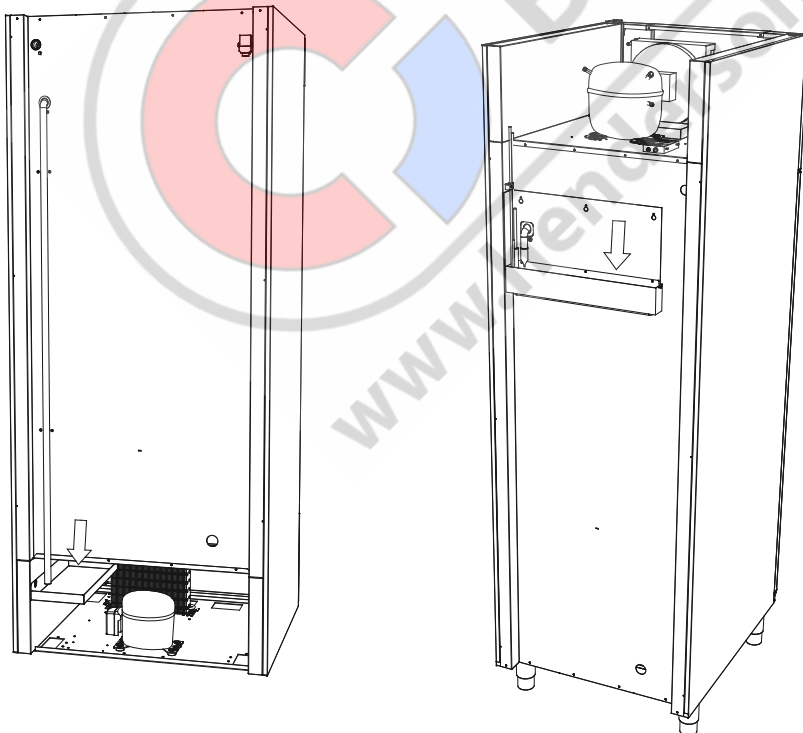

Door closing mechanism

Please note that BioMidi/BioPlus cabinets are equipped with doors that have a self-closing mechanism.

The door is equipped with an automatic closing mechanism. Open the door up to 90°, and it will shut by itself. Open the door more than 90° and door will remain open.

Access port

All BioLine cabinets are equipped with an access port on the back of the cabinets, this can be used to easily fit external sensors and the like.

The illustration below shows an access port on a BioPlus 600 cabinet.

All access ports are constructed in the same fashion, with a conical polystyrene plug (fitted from the back of the cabinet) and a plastic cap (fitted from the inside of the cabinet).

Please note, it is very important to re-fit the polystyrene plug and plastic cap after mounting sensor, probe etc. Failing to do so can result in lowered performance or break-down of the cabinet.

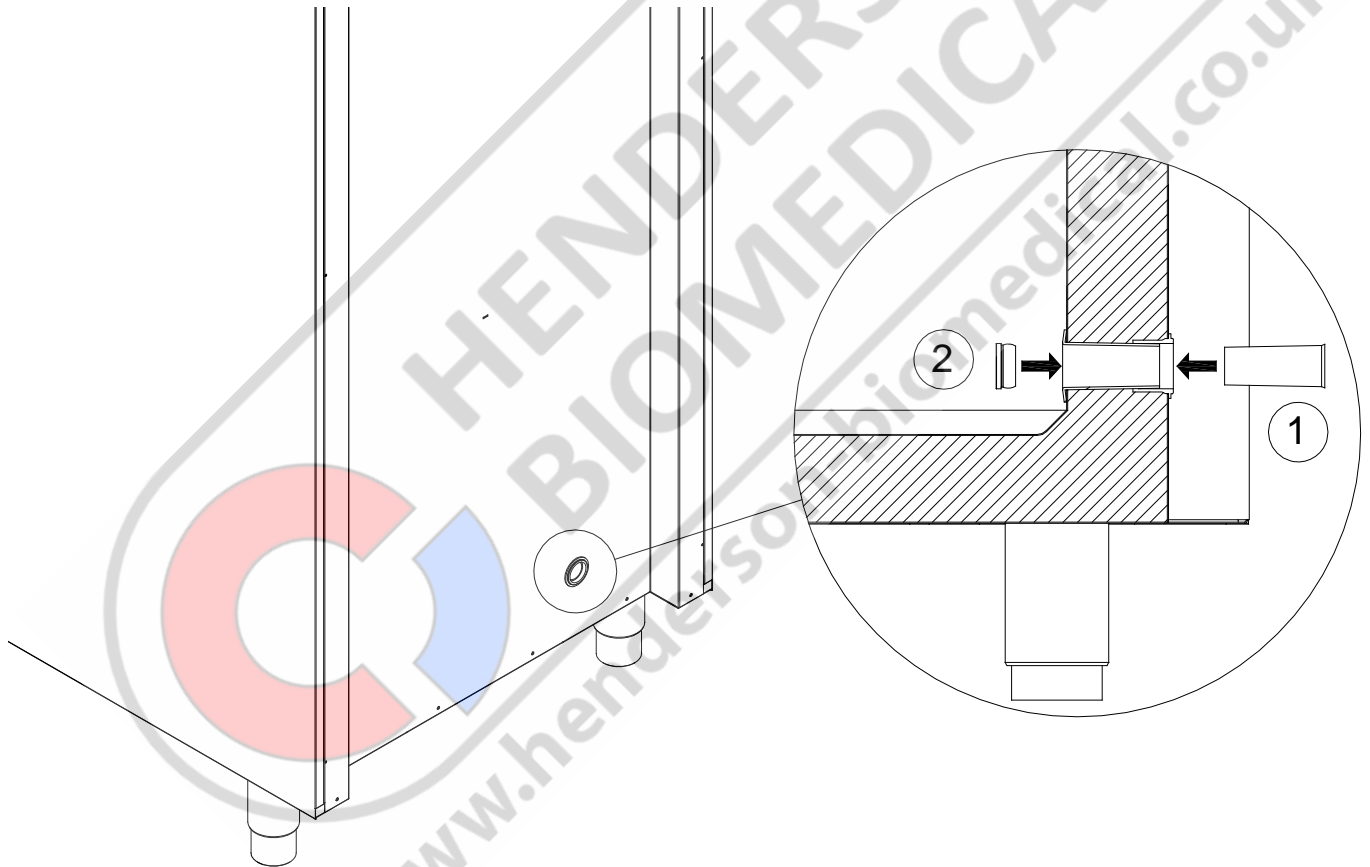

The following part briefly covers the Gram Datalogger

Gram Data Logger allows you to monitor the temperature through our MPC controller.

The collected logs can be downloaded on a computer and read from there.

It is also possible to set up alerts that make notifications if the cabinet exceeded temperature limits (set by the user).

For more information, as well as a manual for the Gram Data Logger, go to: www.gram-bioline.com -> Download



Important

Declaration of conformity



Important!

1. There may occur sharp edges on the cabinet housing, compressor room, and interior furnishings. Show due diligence when handling the cabinet, neglect of these precautions can lead to injuries.
2. Danger of wedging of body parts in the frame slot between the door and the cabinet, show due diligence when opening and closing the cabinet door. Negligence of these precautions can lead to injuries.
3. Danger of wedging of body parts in the drawer column between the drawers and interior of the cabinet, show due diligence when using the drawers. Negligence of these precautions can lead to injuries.
4. Be particularly vigilant in relation to closing doors with self-close mechanism as these are spring-loaded. Negligence of these precautions can lead to injuries.
5. Unlocked castors can lead to unexpected movements of the cabinet. Lock the castors after installation. Negligence of these precautions can lead to injuries.
6. The re-evaporation tray, re-evaporation tray heating element, pressure pipes and compressors develops considerable heat during operation. Assure yourself that these components are sufficiently tempered before touching. Negligence of these precautions can lead to injuries.
7. The evaporator develops considerable cold during operation. Reassure yourself that the evaporator is sufficiently tempered before touching. Negligence of this precaution may lead to injuries.
8. The fan may cause injury during operation, avoiding touching the fans while the cabinet is connected to the mains. Negligence of these precautions can lead to injuries.

Declaration of conformity is readily available for all BioLine cabinets.

Find declaration of conformity for the cabinet at: www.gram-bioline.com

Disposal



Electrical and electronic equipment (EEE) contains materials, components and substances that can be dangerous and harmful to human health and the environment if the waste (WEEE) is not disposed of properly.



Products that are labelled with a "crossed-out wheeie bin" is electric and electronic equipment. The crossed out wheeie bin symbolizes that waste of this type can not be disposed of with unsorted municipal waste, but must be collected separately.



Contact you local BioLine distributor when the cabinet needs to be disposed of.

For additional information, see our website:

www.Gram-Bioline.com







Gram Commercial A/S
Aage Grams Vej 1 • 6500 Vojens • Danmark
Tel: +45 73 20 13 00 • Fax: +45 73 20 12 01
e-mail: info@gram-bioline.com
www.gram-bioline.com



Biostorage you can depend on



LABORATORY EQUIPMENT MAINTENANCE, REPAIR, CALIBRATION AND SALES

Established in 1987, Henderson Biomedical is the UK's leading laboratory equipment sales and service provider. Our knowledgeable team can provide you with excellent sales advice on a range of different types of laboratory equipment including centrifuges, refrigerators, freezers and heat sealers.

Henderson Biomedical is also able to provide you with first class after-sales service and calibration of your laboratory equipment. We are an **ISO 17025 (UKAS) accredited calibration test laboratory** and our team of Field Service Engineers cover the whole of the United Kingdom.

Please contact us for more information on the types of equipment we supply and the different after-sales services we can offer.

Henderson Biomedical

Unit 3, Swan Close
Croydon CR0 2DZ
United Kingdom

Tel: 020 8663 4610

**For sales enquiries: sales@henderson-biomedical.co.uk
For all other enquiries: info@henderson-biomedical.co.uk
www.henderson-biomedical.co.uk**

