



**Translation
Original – Instruction for use**



HENDERSON
BIOMEDICAL
www.henderson-biomedical.co.uk



ENGLISH

1	INTRODUCTION	4
1.1	PREFACE	4
1.2	LEGEND.....	4
1.3	IMPORTANT NOTICE	5
1.4	SAFETY INSTRUCTIONS	6
2	BEFORE STARTING	8
2.1	INTENDED USE.....	8
2.2	DESIGN AND FUNCTIONS	9
2.3	SEALING AND PRINTING PROCESS SEQUENCE	10
2.4	INSTALLATION INSTRUCTIONS AND COMMISSIONING.....	11
2.4.1	Installation	11
2.4.2	Commissioning.....	11
3	CONFIGURATION OF THE MACHINE	12
3.1	AFTER SWITCHING ON.....	12
3.2	PROGRAMMING AIDS.....	13
3.3	DATA INPUT.....	14
3.3.1	Sealing temperature entry.....	14
3.3.2	Expiry date entry	14
3.3.3	User name entry	14
3.3.4	Batch data entry.....	15
3.3.5	Set batch counter.....	15
3.3.6	Set batch counter to zero.....	15
3.3.7	CE information entry	15
3.3.8	Text entry.....	16
3.4	OPERATOR LOGON, MACHINE SETTINGS.....	17
3.4.1	Display contrast	17
3.4.2	Language selection.....	17
3.4.3	Indication of standard print data.....	17
3.4.4	Selection of unit of dimension	17
3.4.5	Selection of date format	17
3.4.6	Change of date or time.....	18
3.4.7	Sealing temperature switch-off tolerance entry.....	18
3.4.8	Display of absolute batch counter.....	18
3.4.9	Display of operating hours	18
3.5	PRINTER SETTINGS.....	19
3.5.1	Print data.....	19
3.5.2	Switch printer off or on	20
3.5.3	Print format.....	21
3.6	OPERATION AND SEALING PROCESS	22
3.7	SEALING SEAM TEST – “SEAL CHECK”	23
3.7.1	Activate and start SEAL CHECK function.....	24

hm 850 DC-V	Contents	
-------------	----------	--

4	TROUBLESHOOTING AND MAINTENANCE	25
4.1	TROUBLESHOOTING CHECKLIST	25
4.2	ERROR DISPLAYS	27
4.3	HAWO CUSTOMER SERVICE	27
4.4	MAINTENANCE INDICATOR	28
4.5	SERVICING / CALIBRATION	28
4.6	PARTS SERVICE	28
4.7	REPLACEMENT PARTS ORDER – ALLOCATION OF ARTICLE NUMBERS	31
4.8	INFORMATION ABOUT REPLACING WEARING AND SPARE PARTS	32
4.8.1	Replacing ink ribbon	32
4.8.2	Replacing PTFE strip on guide rail	33
4.8.3	Replacing PTFE strip for upper and lower heating die	34
4.8.4	Replacing pressure roller	35
4.9	SERVICE SETTINGS	36
4.9.1	Activate service menu	36
4.9.2	Adjusting contact pressure	37
4.9.3	Adjusting temperature control	38
4.9.4	Setting the margin	39
4.9.5	Maintenance date entry	40
4.9.6	Setting of the standby function	40
4.9.7	Activation of default settings	40
5	TECHNICAL DATA	41
5.1	CIRCUIT DIAGRAM AND WIRING DIAGRAM	41
5.2	SPECIFICATIONS	41
6	DECLARATIONS OF CONFORMITY	43
6.1	EC- DECLARATION OF CONFORMITY	43
6.2	DIN EN ISO 11607-2 / DIN 58953-7 DECLARATION OF CONFORMITY	44
7	VALIDATION	45
7.1	GENERAL	45
7.2	PREPARATION	45
7.3	VALIDATION	46
7.3.1	Validation schedule information	46

hm 850 DC-V	Introduction	Chapter 1
-------------	--------------	-----------

1 Introduction

1.1 Preface

First of all we would like to thank you for purchasing the sealing machine. In these instructions you will find information about using the machine, servicing and care as well as process validation.

The sealing machine is a microprocessor controlled rotary sealer with printer for packaging sealable pouches and reels (SBS¹).

The sealing machine meets the requirements of DIN 58953-7, DIN EN ISO 11607-2 and the resulting DGSV² guideline for validating the sealing process.



Please read these operating instructions carefully before commissioning so that you are familiar with the capabilities of the machine and you can make optimum use of its functions.



Always keep these instructions close to the machine.

1.2 Legend

	The exclamation mark in the triangle draws your attention to important notes in the operating instructions, which must absolutely be observed.
	This warning sign refers to measures that could result in danger to human health if they are not observed. It is compulsory to observe it.
	Tips with a hand symbol next to them, which relate to daily practice.

¹ Sterile Barrier System

² Deutsche Gesellschaft für Sterilgutversorgung e.V.

1.3 Important notice



In accordance with the intended use, the CE marking is displayed based on the following EU directives:

2006/42/CE, 2006/95CE and 2004/108/CE.

Medical machine directive 93/42/CE is not applicable to sealing machines.

The limit values of IEC 60601-1 must not be applied in repeated electrical inspections.

The manufacturer accepts no liability whatsoever for damage caused by tests in accordance with standards not listed in the declaration of conformity.

In the event of conversion work or interventions to the machine undertaken without the express written permission of the manufacturer, the warranty shall be deemed void and any liability for physical or material damage shall be transferred to the operator.

Note

Because we are constantly improving our products, we reserve the right to modify these operating instructions and the functions described in them.

These operating instructions apply to products from software version P242A06 onwards

1.4 Safety instructions



1. Our products left the plant in perfect safety condition.
2. To maintain this condition, the content of these safety instructions as well as type plates, labeling and safety instructions attached to the machine must be observed while handling the machine (transport, storage, installation, commissioning, operation and maintenance).
3. This machine is suitable for processing laminated films in the heat-sealing process. See also chapter 2.1 "Intended use".
4. Please check the packaging and lodge a complaint for any damage with the carrier or parcel service immediately before installing the machine.
5. Before commissioning, ensure that the machine does not show any evidence of damage. In case of doubt, contact the manufacturer or a service partner authorised by the manufacturer.
6. Do not operate the machine if the power cable or the power plug is damaged. Do not use the machine if it does not operate correctly or it is damaged in any way. If the mains cable or the machine have been damaged, the machine must be repaired by the manufacturer or by one of the manufacturer's authorised service partners.
7. The machine must be connected using the mains cable included in shipment to a protective contact socket with a stable voltage. Operation on IT networks is not permitted.
8. Please place the machine on a stable base.
9. The machine must not be installed and operated in explosive areas.
10. If the sealing machine is brought directly from a cold environment into a hot environment, condensation may form. Wait until temperature equalisation has taken place.
Starting up the machine when it contains condensation causes danger to life!
11. Fuse changes and repairs must only be performed by the manufacturer or by one of the manufacturer's authorised service partners.
12. Switch off the machine when it is not in use or remove the power plug from the socket.

13. Before cleaning: Disconnect from the mains! Clean the machine only with a dry or damp soft cloth and a mild cleaning agent. Do not allow any water to find its way into the machine. Caution! Never wet clean the machine!
14. Do not insert pointed or flat items into the import slot of the machine. This can result in damage to the machine and instruments.
15. Do not insert items into the louvers of the machine. You might receive an electric shock or the machine could be damaged.
16. Do not use the machine if you have any doubts about machine safety.
17. The machine must not be installed or operated by persons under 16 years of age.
18. The machine must not be operated unsupervised.
19. It is forbidden to operate the machine under the influence of drugs or alcohol.
20. Keep your hair, clothing and gloves away from moving parts!
Loose clothes, jewellery or long hair can be caught in moving parts.
21. Your appliance contains valuable materials which can be recovered or recycled. Leave it at a local civic waste collection point. This appliance is labeled in accordance with European Directive 2002/96 EC concerning used electrical and electronic appliances equipment-WEEE).
The directive determines the framework for the return and recycling of used appliances as applicable throughout the EU.



2 Before starting

2.1 Intended use

The machine is intended only for commercial and industrial use and must only be used for the intended use and with the following materials.

Sealable materials

Pouches and reels in accordance with EN 868-5 and EN ISO 11607-1*

Paper pouches in accordance with EN 868-4*

Uncoated HDPE*

Aluminum laminate film

* also with side gusset

The correct sealing temperature must be identified by means of test sealings (DIN 58953-7).

The machine output depends on the condition of the sealing material used.

Non-sealable materials

polyethylene films

Soft PVC films

Hard PVC foils

Polyamide films

Polypropylene films

2.2 Design and functions

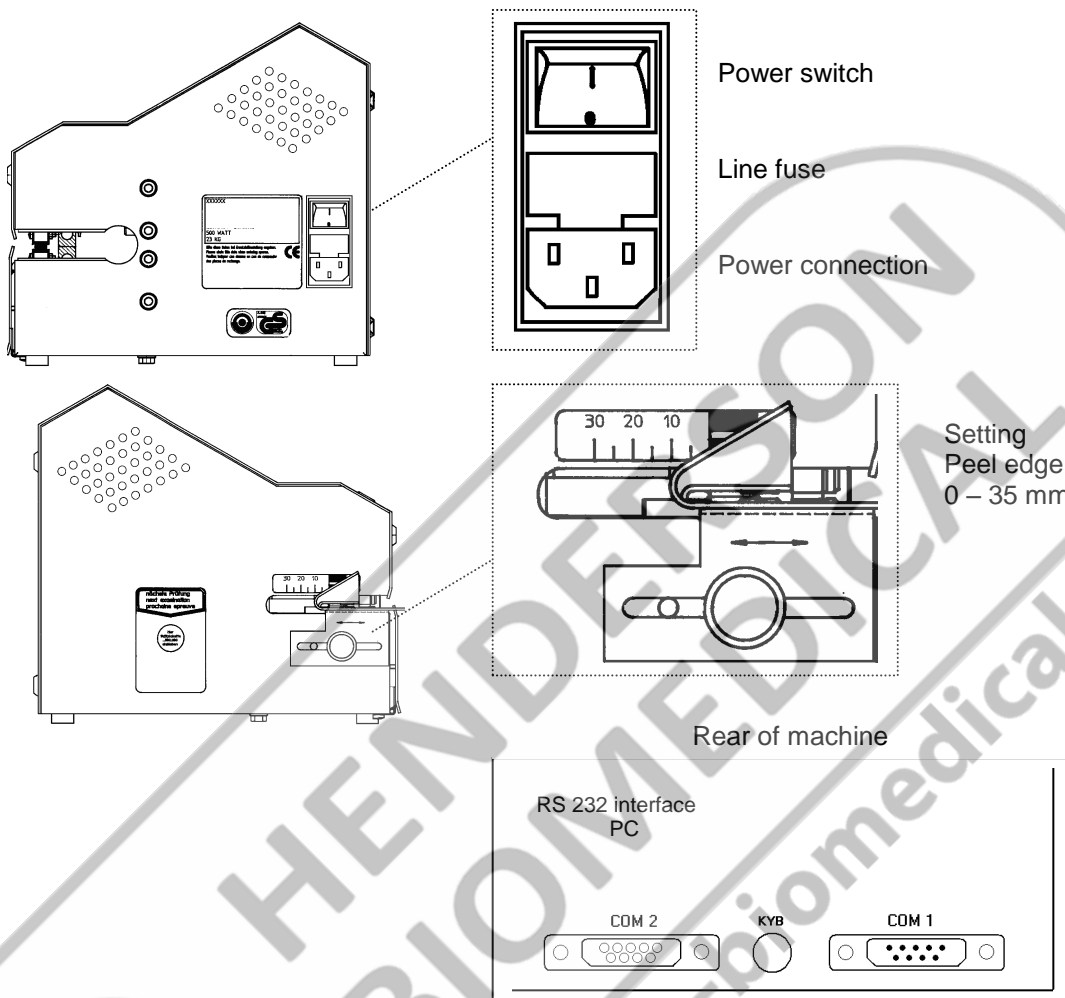

2.3 Sealing and printing process sequence

1. After the sterilisation packaging has been inserted, the feed process is started automatically by means of photoelectric cell. The sealing speed is monitored.
2. The sterilisation packaging is now fed and the sealing seam area is heated up to the set sealing temperature by the heating units located at the top and bottom. The sealing temperature is monitored.
3. The sealing seam, which is now heated, is pressed together by the sealing roller and sealed. The contact pressure is monitored.
4. The printing process is triggered by means of a photoelectric cell when the pressure is switched on and the activated print data is printed onto the sealed packaging.
5. The finished sterilisation packaging is transported to the extraction side.
6. If no item to be sealed is fed in, the feed switches off after approximately 30 seconds.
7. The set parameters remain saved after the machine is switched on or off, or after a power failure. The date and time are updated automatically (Autosafe).



2.4 Installation instructions and commissioning



Prior to installation, read the safety instructions in chapter 1.4

2.4.1 Installation

Place the machine on a horizontal surface.

- ❶ Please do not lift the machine by the infeed section.
- ❷ The distance from the machine to a wall must be at least 200 mm.

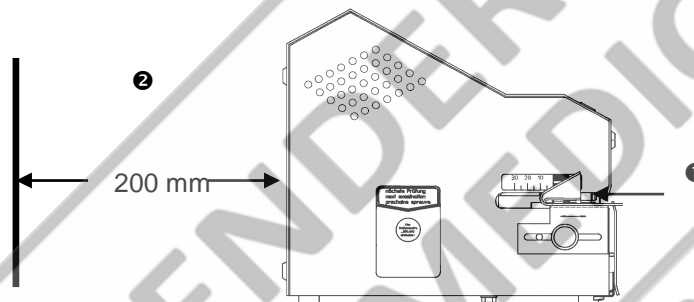

2.4.2 Commissioning

- Connect the mains cable to the mains
- Plug the mains plug into a socket
- Switch the machine on using the power switch

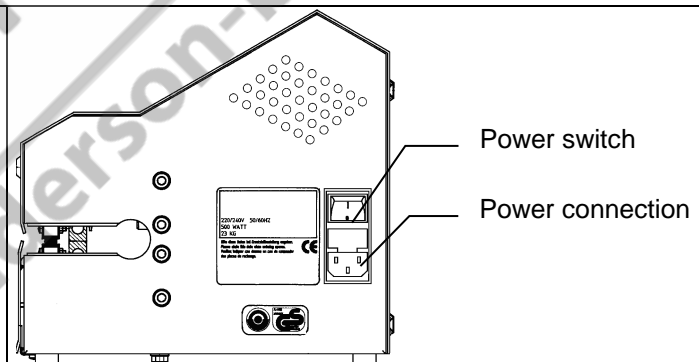

To switch on the machine, press the power switch on the right-hand side.

After a short self-test and after the selected sealing temperature has been reached, the machine is operational. This is indicated by the "Nominal temperature" display going out (see chapter 3.1).

hm 850 DC-V	Configuration of the machine	Chapter 3
-------------	------------------------------	-----------

3 Configuration of the machine

3.1 After switching on

Switch on machine
Self-test runs for approx. 30s

Default settings
When the machine is switched on for the very first time, the following defaults must be undertaken:

Language

Unit of measurement

Date and time

Display for approx. 5 s
Program version P242A06
Serial number 440001

Display of

Date and time

Nominal temperature

Actual temperature

d,t

Tn

Ta

The set nominal temperature is reached after about 3 - 4 min, and the machine is ready

Maintenance note
If this display appears, please refer to the maintenance notes on page 27

hm 850 DC-V

↑

↓

↑

↓

↑

↓

Language selection:
D,GB,F,I,E,SF
S,PL,CZ,TR

EU
Temperature [°C]
Pressure applied [N]
Throughput rate [m/min]

US
Temperature [°F]
Pressure applied [lbf]
Throughput rate [ft/min]

Change date or time

OK

OK

OK

OK

OK

Language
D

units of measure
EU

units of measure
US

DD-MM-YY hh:mm
18-02-10 14:43

Control P242A06
440001

d t Ta

17-02-10 14:30 025 °C

Nominal temp 180 °C

↑
Tn









17-02-10 14:30 180 °C

MAINTENANCE

☞ Pressing the OK button makes it possible to continue working with the machine

hm 850 DC-V	Configuration of the machine	Chapter 3
-------------	------------------------------	-----------









3.2 Programming aids

<p>Cursor control e.g. Press right arrow key once</p>	<p>  Cursor left Cursor right  1x  </p>	<p>100°C ▲ Cursor flashes in 1st position</p> <hr/> <p>100°C ▲ Cursor flashes in 2nd position</p>
<p>Change numbers and letters e.g. Press Position +1 key once</p>	<p>  Position +1 Position -1  1x  </p>	<p>100°C ▲</p> <hr/> <p>110°C ▲</p>
<p>Input is not activated, return to previous menu</p>		<p></p>
<p>Input is activated</p>		<p></p>
<p>Deletes character Batch counter to 0</p>		<p></p>













hm 850 DC-V	Configuration of the machine	Chapter 3
-------------	------------------------------	-----------

3.3 Data input









3.3.1 Sealing temperature entry

 <p>It is possible to enter 3 different sealing temperatures</p> <p>Temperature ranges 1 80 - 220 °C / 302 - 428 °F 2 80 - 220 °C / 302 - 428 °F 3 80 - 220 °C / 302 - 428 °F</p>	 1. Press key  2. Select temperature number for example Temperature 2   3. Enter temperature for example 135°C 	<div data-bbox="1077 376 1345 443" style="border: 1px solid black; padding: 2px;">nominal temp. 180°C +-5°C</div> <div data-bbox="1077 454 1345 521" style="border: 1px solid black; padding: 2px;">nominal temp. 180°C +-5°C 2 </div> <div data-bbox="1077 622 1345 689" style="border: 1px solid black; padding: 2px;">nominal temp. 135°C +-5°C 2 </div> <div data-bbox="1077 701 1345 768" style="border: 1px solid black; padding: 2px;">17-02-10 14:43 135°C</div>
---	--	--

3.3.2 Expiry date entry





 <p>It is possible to enter 3 different dates</p> <p>Factory setting: 1 = today's date + 1 month 2 = today's date + 3 months 3 = today's date + 6 months</p> <p> The date is printed automatically</p>	 1. Press key  2. Select date number for example Date 2   3. Enter new date for example 17-04-10 	<div data-bbox="1077 862 1345 929" style="border: 1px solid black; padding: 2px;"> 17-03-10</div> <div data-bbox="1077 974 1345 1041" style="border: 1px solid black; padding: 2px;"> 17-05-10 2 </div> <div data-bbox="1077 1108 1345 1176" style="border: 1px solid black; padding: 2px;">DD-MM-YY 17-04-10 2 </div> <div data-bbox="1077 1187 1345 1254" style="border: 1px solid black; padding: 2px;">17-02-10 14:43 135°C  17-04-2010</div>
---	---	--

3.3.3 User name entry





 <p>It is possible to enter 20 alphanumerical characters</p> <p> The user name is printed automatically</p>	 1. Press key  2. Enter name 	<div data-bbox="1077 1370 1345 1438" style="border: 1px solid black; padding: 2px;"></div> <div data-bbox="1077 1460 1345 1527" style="border: 1px solid black; padding: 2px;"> MILLER </div> <div data-bbox="1077 1550 1345 1617" style="border: 1px solid black; padding: 2px;">17-02-10 14:43 135°C  MILLER</div>
---	--	---

hm 850 DC-V	Configuration of the machine	Chapter 3
-------------	------------------------------	-----------





3.3.4 Batch data entry

<p>LOT CHARGE</p> <p>It is possible to enter 10 alphanumerical characters</p> <p> The batch data is printed automatically</p>	<p>LOT CHARGE</p> <p>1. Press key </p> <p>2. Enter batch data </p>	<p>LOT</p> <p>LOT AB123 </p> <p>17-02-10 14:43 135 °C LOTAB123</p>
---	---	--









3.3.5 Set batch counter

<p>1.2.3. COUNT</p> <p>7 numbers can be entered</p> <p> The batch counter is printed automatically</p>	<p>1.2.3. COUNT </p> <p>1. Press keys one after another </p> <p>2. Set batch counter, e.g. to 0001000 </p>	<p>piece counter</p> <p>piece counter 0001000 </p> <p>17-02-10 14:43 135 °C 0001000</p>
--	--	--

3.3.6 Set batch counter to zero







<p>1.2.3. COUNT</p> <p> The batch counter is printed automatically</p>	<p>1.2.3. COUNT </p> <p>1. Press keys one after another </p> <p>2. Set batch counter to 0000000</p>	<p>piece counter</p> <p>piece counter 0000000 </p> <p>17-02-10 14:43 135 °C 0000000</p>
--	--	--

3.3.7 CE information entry

<p> </p> <p>It is possible to enter 20 alphanumerical characters</p> <p> The CE information is printed automatically</p>	<p> </p> <p>1. Press keys one after another</p> <p>2. Enter CE information </p> <p></p>	<p>CE- info</p> <p>CE- info EN 294 </p> <p>17-02-10 14:43 135 °C CE EN 294</p>
---	---	---

hm 850 DC-V	Configuration of the machine	Chapter 3
-------------	------------------------------	-----------

3.3.8 Text entry



 <p>It is possible to enter 20 alphanumerical characters</p>  <p>The text is printed automatically</p>	 1. Press key  2. Enter text 	<div data-bbox="1082 336 1345 403" style="border: 1px solid black; padding: 2px;">text input</div> <div data-bbox="1082 425 1345 492" style="border: 1px solid black; padding: 2px;">text input Text</div> <div data-bbox="1082 515 1345 582" style="border: 1px solid black; padding: 2px;">17-02-10 14:43 135°C Text</div> 
--	--	--



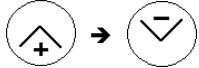

hm 850 DC-V	Configuration of the machine	Chapter 3
-------------	------------------------------	-----------

3.4 Operator logon, Machine settings





3.4.1 Display contrast

<p>Press the keys one after another</p> 	 Contrast ↑  Contrast ↓	<div style="border: 1px solid black; padding: 5px; display: inline-block;">display - contrast</div> <div style="border: 1px solid black; border-radius: 50%; width: 40px; height: 40px; display: flex; align-items: center; justify-content: center; margin-left: 10px;">OK</div>
---	--	---



3.4.2 Language selection

<p>Press the keys one after another</p> 	 Language selection: D,GB,F,I,E,SF S,PL,CZ,TR 	<div style="border: 1px solid black; padding: 5px; display: inline-block;">set language GB</div> <div style="border: 1px solid black; border-radius: 50%; width: 40px; height: 40px; display: flex; align-items: center; justify-content: center; margin-left: 10px;">OK</div>
---	---	--



3.4.3 Indication of standard print data

<p>Press the keys one after another</p> 	 Yes Indication for date, expiry, batch Operators are printed as a symbol acc. to EN 980 	<div style="border: 1px solid black; padding: 5px; display: inline-block;">pictogramm YES</div> <div style="border: 1px solid black; border-radius: 50%; width: 40px; height: 40px; display: flex; align-items: center; justify-content: center; margin-left: 10px;">OK</div>
	 No Identification for date, expiry, batch. Operators are printed as text	<div style="border: 1px solid black; padding: 5px; display: inline-block;">pictogramm NO</div> <div style="border: 1px solid black; border-radius: 50%; width: 40px; height: 40px; display: flex; align-items: center; justify-content: center; margin-left: 10px;">OK</div>

3.4.4 Selection of unit of dimension



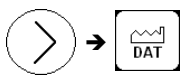

<p>Press the keys one after another</p> 	 EU Temperature [°C] Pressure applied [N] Throughput rate [m/min]	<div style="border: 1px solid black; padding: 5px; display: inline-block;">unit of measure EU</div> <div style="border: 1px solid black; border-radius: 50%; width: 40px; height: 40px; display: flex; align-items: center; justify-content: center; margin-left: 10px;">OK</div>
	 US Temperature [°F] Pressure applied [lbf] Throughput rate [ft/min]	<div style="border: 1px solid black; padding: 5px; display: inline-block;">unit of measure US</div> <div style="border: 1px solid black; border-radius: 50%; width: 40px; height: 40px; display: flex; align-items: center; justify-content: center; margin-left: 10px;">OK</div>

3.4.5 Selection of date format







<p>Press the keys one after another</p> 	 Selection of date format: 	<div style="border: 1px solid black; padding: 5px; display: inline-block;">format date & time DD-MM-YYYY</div> <div style="border: 1px solid black; border-radius: 50%; width: 40px; height: 40px; display: flex; align-items: center; justify-content: center; margin-left: 10px;">OK</div> <div style="border: 1px solid black; border-radius: 50%; width: 40px; height: 40px; display: flex; align-items: center; justify-content: center; margin-left: 10px;">OK</div>
---	---	---

hm 850 DC-V	Configuration of the machine	Chapter 3
-------------	------------------------------	-----------

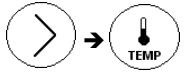

3.4.6 Change of date or time

<p>Press the keys one after another</p> 	<p>Change date or time</p>   <div data-bbox="1077 380 1348 459" style="border: 1px solid black; padding: 2px;"> DD-MM-YY hh:mm 18-02-10 14:43 </div> 
---	---

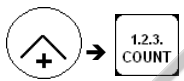

3.4.7 Sealing temperature switch-off tolerance entry

<p>Press the keys one after another</p>  <p>Allocation of a temperature tolerance limit which, if violated, results in the motor being stopped automatically.</p> <p>Range $\pm 2^{\circ}\text{C}$ to $\pm 5^{\circ}\text{C}$ Factory setting $\pm 5^{\circ}\text{C}$</p>	<p>1. Select temperature number for example Temperature 2</p>   <div data-bbox="1077 616 1348 683" style="border: 1px solid black; padding: 2px;"> tolerance limit 180°C $\pm 5^{\circ}\text{C}$ </div> <div data-bbox="1077 683 1348 750" style="border: 1px solid black; padding: 2px;"> Nominal temperature 135°C $\pm 5^{\circ}\text{C}$ 2 </div>  <p>2. Enter tolerance limit for example $\pm 3^{\circ}$</p>   <div data-bbox="1077 851 1348 918" style="border: 1px solid black; padding: 2px;"> tolerance limit 135°C $\pm 3^{\circ}\text{C}$ 2 </div> 
--	--

3.4.8 Display of absolute batch counter

<p>Press the keys one after another</p> 	<div data-bbox="1077 1108 1348 1176" style="border: 1px solid black; padding: 2px;"> absolute p. counter 0000020 </div> 
---	--

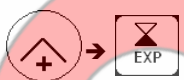
3.4.9 Display of operating hours

<p>Press the keys one after another</p> 	<div data-bbox="1077 1388 1348 1456" style="border: 1px solid black; padding: 2px;"> operating time 000010 h 38 min </div> 
---	---

hm 850 DC-V	Configuration of the machine	Chapter 3
-------------	------------------------------	-----------

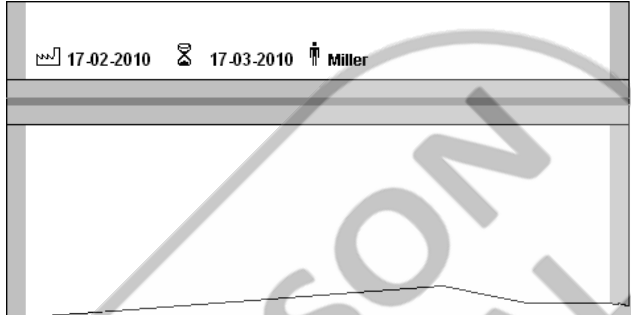

3.5 Printer settings

3.5.1 Print data

<p>The sequence of print data is set and cannot be changed The individual items of information are always printed in this sequence:</p> <ul style="list-style-type: none"> Date of manufacture, time Expiry date Operator name Batch counter or Absolute batch counter Text CE information Machine number Batch data 	<p>For example, printout of sterilisation date, expiry date, personnel number</p> 																																																																																
<p>Date of manufacture</p> <p>Expiry date</p> <p>Batch data</p> <p>Operator name</p> <p>Batch counter</p> <p>Absolute batch counter</p> <p>Machine number</p> <p>Text</p> <p>CE information</p>	<table border="0"> <tr> <td></td> <td style="text-align: center;">Print</td> <td></td> <td style="text-align: center;">Do not print</td> </tr> <tr> <td></td> <td style="text-align: center;"></td> <td style="text-align: center;">OK</td> <td style="text-align: center;"></td> </tr> <tr> <td></td> <td></td> <td style="text-align: center;">18 -02-10</td> <td></td> </tr> <tr> <td></td> <td></td> <td style="text-align: center;"></td> <td style="text-align: center;">DEL</td> </tr> <tr> <td></td> <td style="text-align: center;"></td> <td style="text-align: center;">OK</td> <td style="text-align: center;"></td> </tr> <tr> <td></td> <td></td> <td style="text-align: center;">17-04-10</td> <td style="text-align: center;">DEL</td> </tr> <tr> <td></td> <td style="text-align: center;"></td> <td style="text-align: center;">OK</td> <td style="text-align: center;"></td> </tr> <tr> <td></td> <td></td> <td style="text-align: center;">AB123</td> <td style="text-align: center;">DEL</td> </tr> <tr> <td></td> <td style="text-align: center;"></td> <td style="text-align: center;">OK</td> <td style="text-align: center;"></td> </tr> <tr> <td></td> <td></td> <td style="text-align: center;">MILLER</td> <td style="text-align: center;">DEL</td> </tr> <tr> <td></td> <td style="text-align: center;"></td> <td style="text-align: center;">OK</td> <td style="text-align: center;"></td> </tr> <tr> <td></td> <td></td> <td style="text-align: center;">2x piece counter 000001</td> <td style="text-align: center;">OK DEL</td> </tr> <tr> <td></td> <td style="text-align: center;"></td> <td style="text-align: center;">OK</td> <td style="text-align: center;"></td> </tr> <tr> <td></td> <td></td> <td style="text-align: center;">1x absolute p. counter 0000020</td> <td style="text-align: center;">DEL</td> </tr> <tr> <td></td> <td style="text-align: center;"></td> <td style="text-align: center;">OK</td> <td style="text-align: center;"></td> </tr> <tr> <td></td> <td></td> <td style="text-align: center;">2x serial number 440001</td> <td style="text-align: center;">DEL</td> </tr> <tr> <td></td> <td style="text-align: center;"></td> <td style="text-align: center;">OK</td> <td style="text-align: center;"></td> </tr> <tr> <td></td> <td></td> <td style="text-align: center;">text input Text</td> <td style="text-align: center;">DEL</td> </tr> <tr> <td></td> <td style="text-align: center;"></td> <td style="text-align: center;">OK</td> <td style="text-align: center;"></td> </tr> <tr> <td></td> <td></td> <td style="text-align: center;">CE- info EN 294</td> <td style="text-align: center;">DEL</td> </tr> </table>		Print		Do not print			OK				18 -02-10					DEL			OK				17-04-10	DEL			OK				AB123	DEL			OK				MILLER	DEL			OK				2x piece counter 000001	OK DEL			OK				1x absolute p. counter 0000020	DEL			OK				2x serial number 440001	DEL			OK				text input Text	DEL			OK				CE- info EN 294	DEL
	Print		Do not print																																																																														
		OK																																																																															
		18 -02-10																																																																															
			DEL																																																																														
		OK																																																																															
		17-04-10	DEL																																																																														
		OK																																																																															
		AB123	DEL																																																																														
		OK																																																																															
		MILLER	DEL																																																																														
		OK																																																																															
		2x piece counter 000001	OK DEL																																																																														
		OK																																																																															
		1x absolute p. counter 0000020	DEL																																																																														
		OK																																																																															
		2x serial number 440001	DEL																																																																														
		OK																																																																															
		text input Text	DEL																																																																														
		OK																																																																															
		CE- info EN 294	DEL																																																																														

hm 850 DC-V	Configuration of the machine	Chapter 3
-------------	------------------------------	-----------

3.5.2 Switch printer off or on

Switch off printer		<div data-bbox="900 331 1166 394" style="border: 1px solid black; padding: 2px;"> 17-02-10 14:43 135°C printer off </div>
Switch on printer		<div data-bbox="900 421 1166 483" style="border: 1px solid black; padding: 2px;"> 17-02-10 14:43 135°C </div>



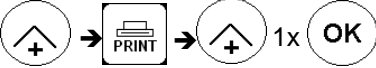

3.5.3 Print format

Activate settings
Press the keys one after another

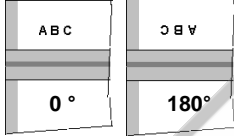

Representation of print format









Printer config.
YES

Print format
0°

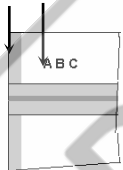

Margin adjustment
Positioning of the print data on the package 0 –99 mm from the edge of the package





distance
02 0-99





Standard character size
Printout of print data in 6 different widths

character width
0 0-5



Character pitch
5 different pitches between the individual characters

character distance
0 0-5



3.6 Operation and sealing process

- The material to be sealed must be sealed according to the manufacturer's instructions.
- Set the peel edge width:
After the locking machine has been loosened, the peel edge can be set by shifting the infeed section variably between 0 mm and 35 mm. A sufficient protrusion must be available between the sealing seam and the reel interface given on the extraction side (in accordance with DIN 58953-7 min. 10 mm).
- Sterilisation package must be inserted from the left-hand side, always with the side to be printed face down.
The drive is switched on automatically.
- Remove the sealed sterilisation packaging and leave briefly to cool.



Sealable pouches and reels must only be filled to $\frac{3}{4}$ full (DIN 58953-7). The limited filling prevents a load that is too large from being placed on the sealing seams.



The correct sealing temperature must be identified by means of test sealings (DIN 58953-7).

Sealing must be performed in such a way that the sealing seam meets the quality characteristics required in EN ISO 11607-2, even with varying material thicknesses. The following quality characteristics must be met:

- Intact sealing across the entire sealing seam width
- No channels or open seals
- No punctures or tears
- No delamination or material separation

hawotest SEAL CHECK is considered suitable for checking these quality characteristics.³ hawotest SEAL CHECK seal indicators are available separately.

³ see the DGSV guideline for validation of the sealing process

3.7 Sealing seam test – “Seal Check”

Testing of the critical process parameters temperature, contact pressure and sealing time with "SEAL CHECK".



Seal Check seal indicators are not suitable for packaging with side folds

This test should be performed before and after the daily working process and/or before/after each load and can be documented by routinely filing the printout (DIN EN ISO 11607-2).

The additional use of the SEAL CHECK sealing indicator in combination with the SEAL CHECK function of the sealing machine is recommended.



Before the test, the machine must be ready for use and the set temperature must have been reached.

hm 850 DC-V	Configuration of the machine	Chapter 3
-------------	------------------------------	-----------

3.7.1 Activate and start SEAL CHECK function

OK

1. Press key

seal check
OK->Start

OK

2. Insert sterilisation package, width min. 200 mm.
If necessary, insert SEAL CHECK indicator strip into the package

seal check
Start

Printing of seal check function

	Sealing temperature	Sealing time	Serial number
16-12-2005 12:31h T: 150°C F: 100N t: 2.8s Miller [402741]			
Date Time Contact pressure Operator name			

hm 850 DC-V	Troubleshooting and maintenance	Chapter 4
-------------	---------------------------------	-----------

4 Troubleshooting and maintenance

4.1 Troubleshooting checklist

 The troubleshooting suggestions marked with an * are only allowed to be carried out by the manufacturer or a service partner authorised by the manufacturer.

Malfunction	Possible cause	Remedy
Machine fails to switch on No data on the display	Power supply Power cable not plugged in Power cable defective Line fuse Control board Indicator card	Check power supply If necessary, plug into a different power outlet Replace power cable Replace line fuse! ! If the fuse blows again, it is imperative to have the machine tested. Replace control board.* Exchange indicator card*
Machine fails to heat up	Set temperature is too low Temperature limitation activated Temperature sensor Heating cartridge Control board	Increase nominal temperature (see pg. 14) Reset temperature limiter by pressing in the pin! If it still trips it is imperative to have the machine tested Replace temperature sensor.* Check heating cartridges and replace if necessary* Replace control board*
No transport	Transport belt - Damaged - No transport Front flap not closed Motor sensor Front flap not closed Motor Control board	Replace transport belt Check belt tension Close front flap Replace light barrier Replace front flap sensor Replace motor* Replace control board*
Uneven material feed or loud running noise	Transport belt guide Transport belt - Damaged - No transport Motor	Renew PTFE belt on guiding die (see pg. 32) Replace transport belt Check belt tension Replace motor*

hm 850 DC-V	Troubleshooting and maintenance	Chapter 4
-------------	---------------------------------	-----------

Malfunction	Possible cause	Remedy
Sealed seam will not hold	Temperature too low	Increased temperature
	Contact pressure too low Sealing die - Distance between the sealing dies too large	Readjust pressure of the sealing roller or replace sealing roller* Set distance of the sealing dies to 0.5 mm*
Sealed seam distorted	Pressure applied too high	Readjust pressure of the sealing roller or replace sealing roller.*
Paper side of the package is discoloured or side fold shrunk	Temperature too high	Reduce temperature (see pg. 14)
No printing or printing incomplete	Programming - Print start not set properly	Reprogram print start (see pg. 21)
	Ink ribbon	Ink ribbon not inserted properly Replace ink ribbon.(see pg. 31)
	Print head	Replace print head
	Control board	Replace control board*
Printing too faint	Ink ribbon	Replace ink ribbon
	Print head	Readjust print head
	Paper pressure roller	Adjust paper pressure roller
No keyboard function	Keyboard	- Check keyboard plug for contact - Renew keyboard
	Indicator card	Exchange indicator card*
	Control board	Replace control board*

hm 850 DC-V	Troubleshooting and maintenance	Chapter 4
-------------	---------------------------------	-----------

4.2 Error displays

 If these error messages are displayed, the first step is to switch the machine off and back on again!

Sealing temperature out of tolerance	flashing	<table border="1"> <tr> <td>17-02-10</td> <td>14:30</td> <td>180 °C</td> </tr> <tr> <td colspan="2">nominal temp.</td> <td>186 °C</td> </tr> </table>	17-02-10	14:30	180 °C	nominal temp.		186 °C
17-02-10	14:30	180 °C						
nominal temp.		186 °C						
Possible cause		Remedy						
Temperature sensor defective		Replace temperature sensor*						
Control board defective		Replace control board*						

Contact pressure out of tolerance	flashing	<table border="1"> <tr> <td>17-02-10</td> <td>14:30</td> <td>180 °C</td> </tr> <tr> <td colspan="2">contact pressure</td> <td></td> </tr> </table>	17-02-10	14:30	180 °C	contact pressure		
17-02-10	14:30	180 °C						
contact pressure								
Possible cause		Remedy						
DMS module not calibrated		Recalibrate DMS module*						
DMS module defective		Replace DMS module*						
Control board defective		Replace control board*						

4.3 hawo customer service



Your hawo customer service is available from Mon-Fri 8:00 - 17:00 CET on the following number: +49 6261 977031.

You are also welcome to send questions to the following e-mail address: service@hawo.com

hm 850 DC-V	Troubleshooting and maintenance	Chapter 4
-------------	---------------------------------	-----------

4.4 Maintenance indicator

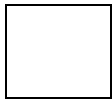

Like all technical machines, your machine is also subject to technical wear. In order to guarantee continuous operational readiness, your machine should be inspected regularly by a competent person and serviced and calibrated at least once per year by the manufacturer or by one of the manufacturer's authorised service partners.

Therefore, the maintenance date of the machine is set to 1 year. If this date is reached, a reminder about the date is given every time the machine is switched on.

<p>Information before reaching the set maintenance date</p> <p>Maintenance date reached</p>	 Pressing the OK button makes it possible to continue working with the machine <div style="float: right; border: 1px solid black; padding: 5px; display: inline-block;"> MAINTENANCE OK </div>
--	---

4.5 Servicing / calibration

Maintenance cycle	Ink ribbon	PTFE tape Guiding punch	PTFE tape Sealing die	Pressure roller	Toothed belt	Clearance Sealing die	Calibration of critical process parameters
At least every 3 months							
Depending on usage, at least once a year							

Legend:

 Check

 Replace

 Adjust

 Measure

4.6 Parts service

 **Simply order parts by fax:**

- Please copy the following pages according to the parts required.
 Page 28: Parts required for maintenance and wear
 Page 29: Replacement parts
- Enter machine number. _____
- Enter machine model. _____
- Enter address, fax number and order number.
- Mark items required.
- Enter quantity required.
- Sign order.
- Fax order.

S/N: 123456
Type: hm 850 DC-V

Bitte diese Daten bei Ersatzteilbestellung angeben.
 Please state this data when ordering spares.
 Veuillez indiquer ces données en cas de commande
 des pièces de rechange.



To:

Sender:

Fax no. _____

Your order no. _____		Date _____	
Machine model _____		Serial number _____	
<input checked="" type="checkbox"/>	Designation	Art. no.	Qty.
<input type="checkbox"/>	Ink ribbon	6.813.104	
<input type="checkbox"/>	Ink ribbon, red	6.813.224	
<input type="checkbox"/>	PTFE tape Sealing die	6.105.285	
<input type="checkbox"/>	PTFE tape Guide rail 500 mm	6.105.139	
<input type="checkbox"/>	Plastic pressure roller	2.230.008	
<input type="checkbox"/>	Toothed belt, drive 375 mm	6.271.011	
<input type="checkbox"/>	Toothed belt Transport Sealing material 480 mm	6.271.008	
<input type="checkbox"/>	Heating cartridge	6.536.032	
<input type="checkbox"/>	Upper sealing die assembly	1.616.028	
<input type="checkbox"/>	Lower sealing die assembly	1.616.029	
<input type="checkbox"/>			
<input type="checkbox"/>			
<input type="checkbox"/>			

Signature _____

To:

Sender:

Fax no.

Your order no. _____		Date _____	
Machine model _____		Serial number _____	
<input checked="" type="checkbox"/>	Designation	Art. no.	Qty.
<input type="checkbox"/>	Print head	1.653.002	
<input type="checkbox"/>	Control board	1.410.088	
<input type="checkbox"/>	Indicator card	1.410.017	
<input type="checkbox"/>	DMS module	1.410.018	
<input type="checkbox"/>	Optosensor	1.561.003	
<input type="checkbox"/>	Gear motor	1.212.011	
<input type="checkbox"/>	Ink ribbon, motor	1.212.012	
<input type="checkbox"/>	Temperature limiter heating cartridge	6.564.018	
<input type="checkbox"/>	Temperature sensor	6.564.023	
<input type="checkbox"/>	Service Dongle	1.561.002	
<input type="checkbox"/>			
<input type="checkbox"/>			
<input type="checkbox"/>			

Signature _____

4.7 Replacement parts order – allocation of article numbers

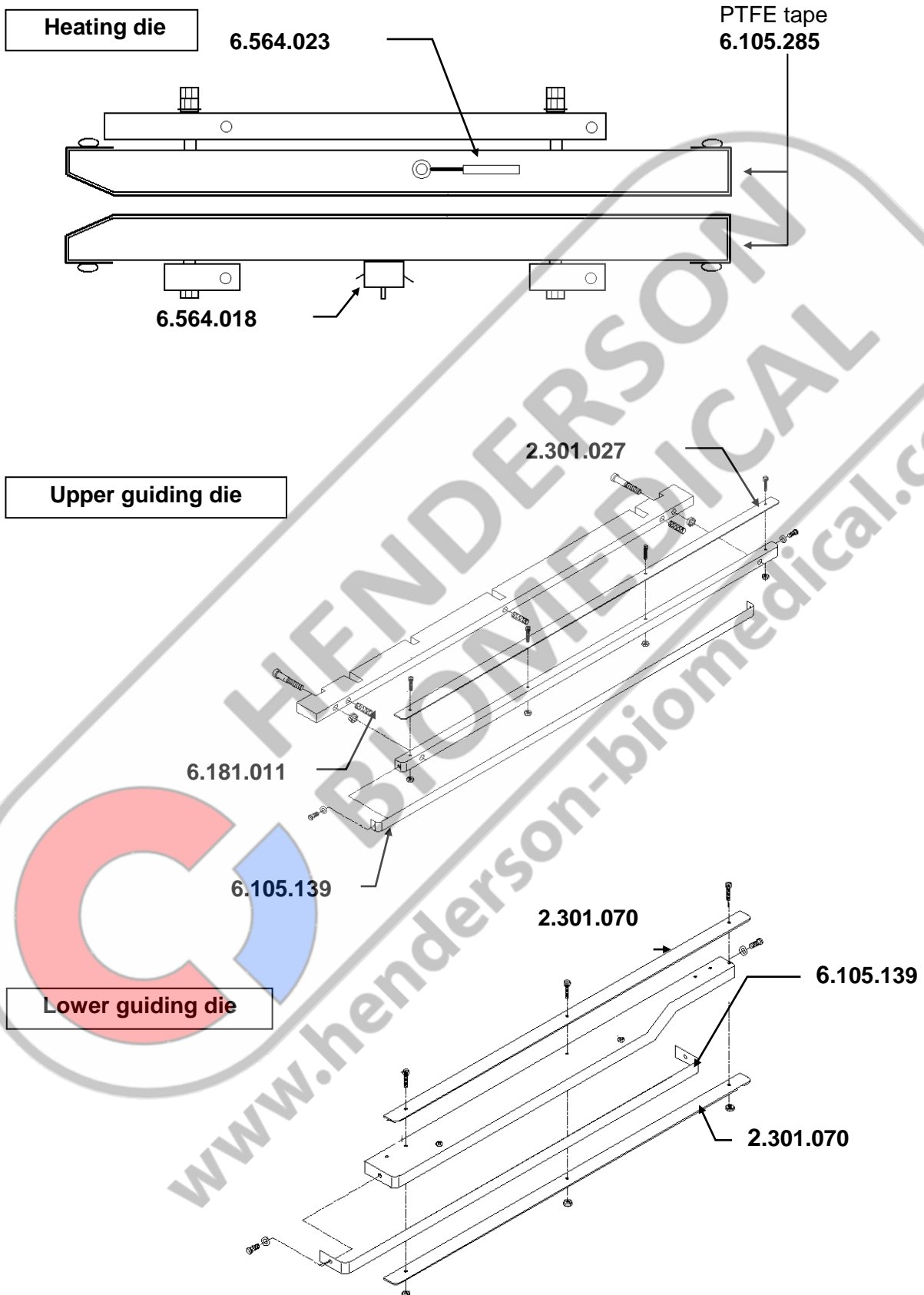

4.8 Information about replacing wearing and spare parts

4.8.1 Replacing ink ribbon

→ Switch off the machine

- Open front flap
- Press lever for ink ribbon holder ❶ down with left hand
- Press holder for ink ribbon cassette ❷ to side and remove cassette
- Insert new ink ribbon cassette

! Please use **only genuine replacement parts**



Always ensure that the transport opening ❸ in the cassette is attached to the transport shaft ❹.

- Press ink ribbon cassette toward rear until holder ❷ catches
- Close front flap

→ Switch on machine and check printing function after reaching nominal temperature

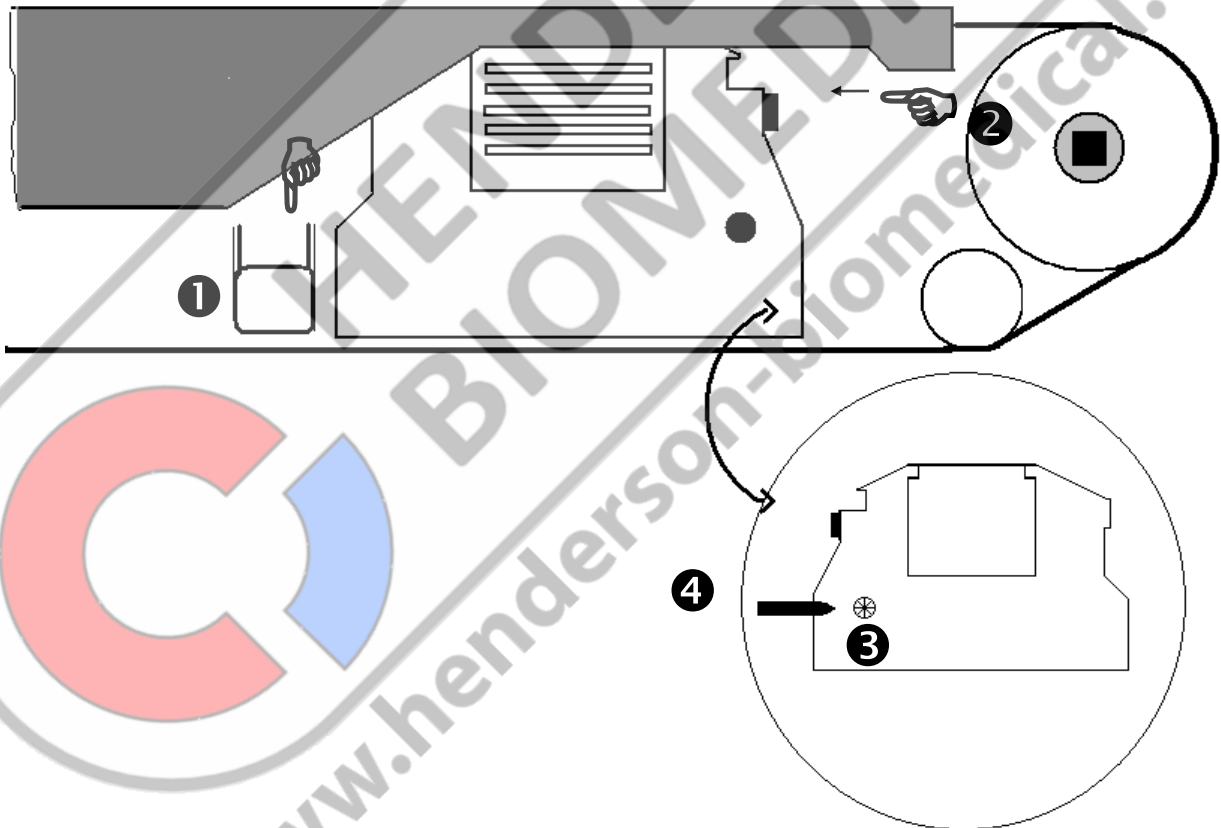

Maintenance information

! Please use **only genuine replacement parts**

4.8.2 Replacing PTFE strip on guide rail

→ Switch off machine and DISCONNECT POWER PLUG!

- Open housing
- Remove mounting screws ❶ for upper guide rail and remove guide rail or
- Remove mounting screws ❷ for lower guide rail and remove guide rail
- Remove mounting screws ❸ and detach PTFE strip
- Pull backing foil off of new PTFE strip and glue new PTFE strip on straight and without wrinkles
- Fasten PTFE strip with screws ❹
- Install guide rails.



When installing the upper guide rail before fastening, push the die down so that the interval between the screw head and rail is 1 mm on both sides. This ensures the correct contact pressure for the guide rail.

- Close housing

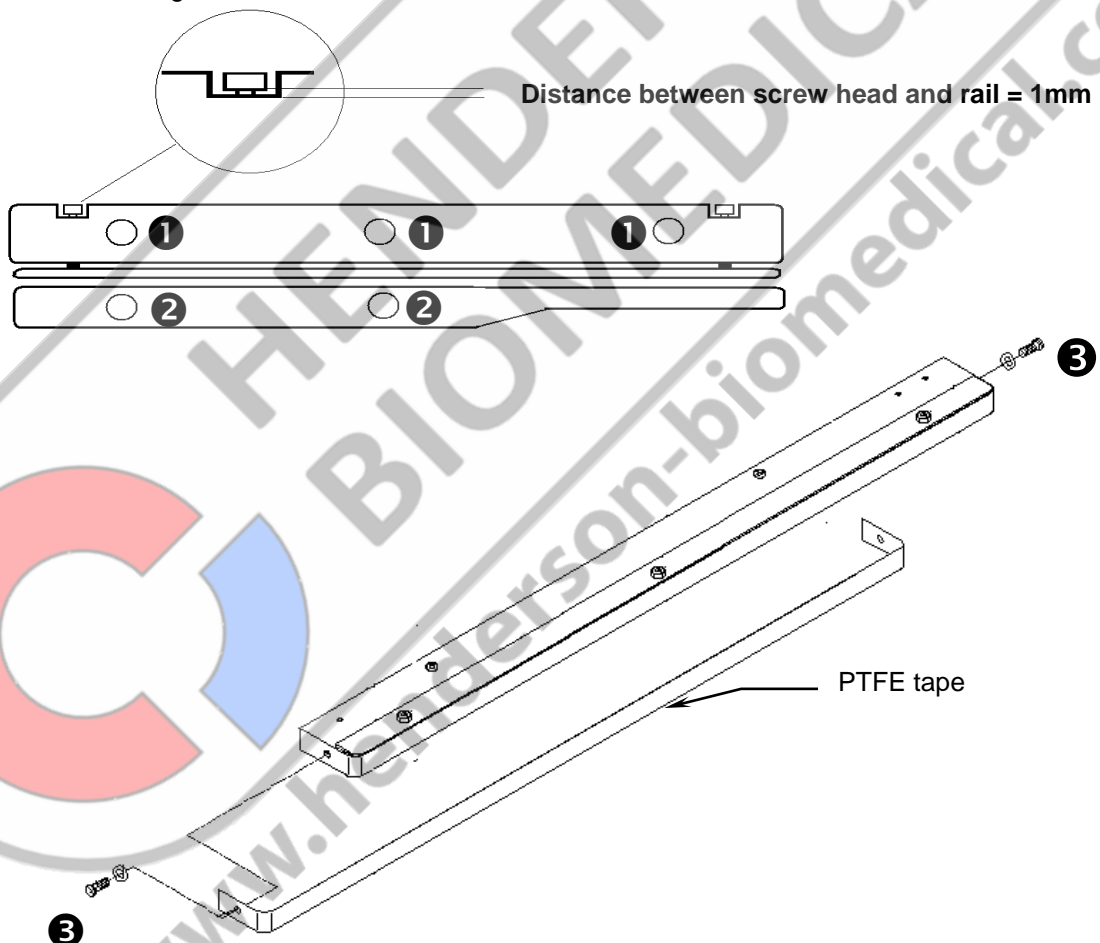

Maintenance information

! Please use only genuine replacement parts

4.8.3 Replacing PTFE strip for upper and lower heating die

➔ **Switch off machine and DISCONNECT POWER PLUG!**

- Open housing
- Remove mounting screws ① for upper guide rail and remove guide rail.

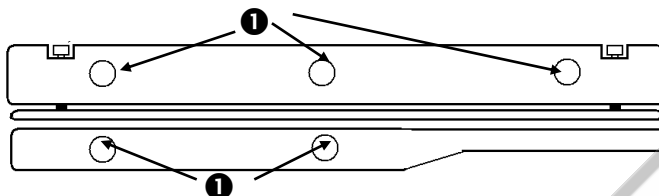

- Disconnect electrical connections for heating die
- Remove fastening screws ④
- Remove top or bottom heating die
- Unscrew mounting screw ⑤ and detach PTFE strip

- Remove backing foil on new PTFE strip and glue new PTFE strip on straight and without wrinkles
- Fasten PTFE strip with screws ⑤
- Install heating die
- Fasten fastening screws ④ of the heating die
- Reconnect electrical connections to heating die

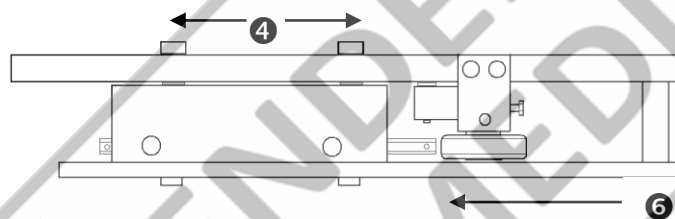

- Detach nuts ⑥
- Set distance between the sealing dies to 0.5 mm
- Fasten nuts ⑥

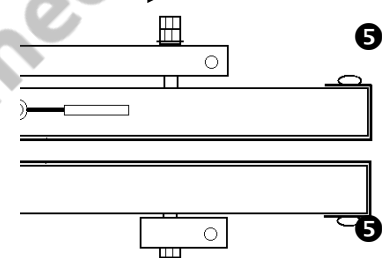
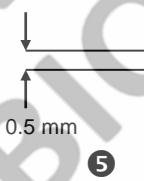

- Install guide rail.

When installing the upper guide rail before fastening, push the die down so that the interval between the screw head and rail is 1mm on both sides. This ensures the correct contact pressure for the guide rail.

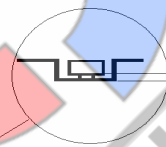

Distance between screw head and rail = 1mm

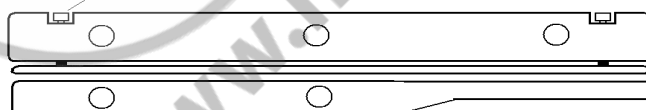

- Close housing

Maintenance information

! Please use only genuine replacement parts

4.8.4 Replacing pressure roller

➔ **Switch off machine and DISCONNECT POWER PLUG!**

- Open housing
- Remove mounting screws **1** for upper guide rail and remove guide rail.
- Unscrew pressure adjustment screw **2** approx. 5 mm
- Loosen mounting screw **3** and pull pressure roller completely out of holder
- Detach snap ring **4** and remove pressure roller
- Install new pressure roller and fasten with snap ring **4**
- Insert pressure roller fully into holder, align centrally with the lower roller
- Tighten mounting screw **3**
- Adjust contact pressure by screwing in adjustment screw **2** according to calibration instructions on page 39

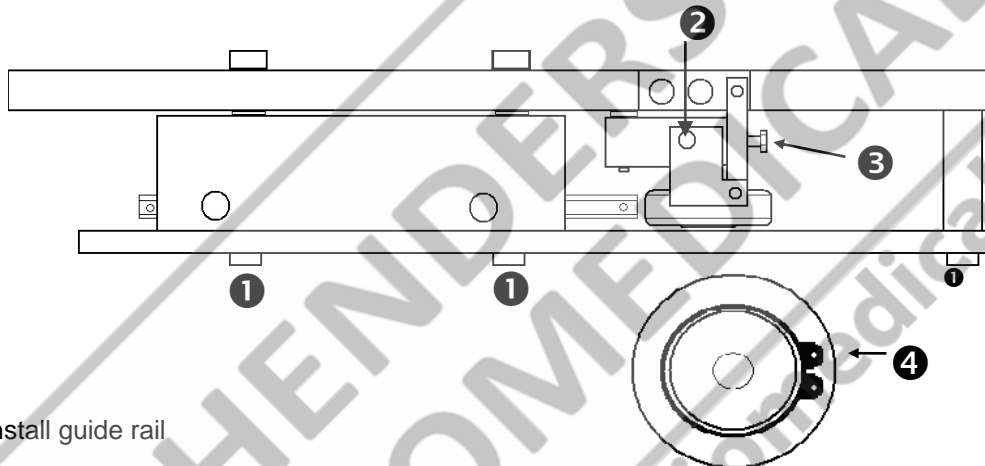

- Install guide rail

When installing the upper guide rail before fastening, push the die down so that the interval between the screw head and rail is 1mm on both sides. This ensures the correct contact pressure for the guide rail.

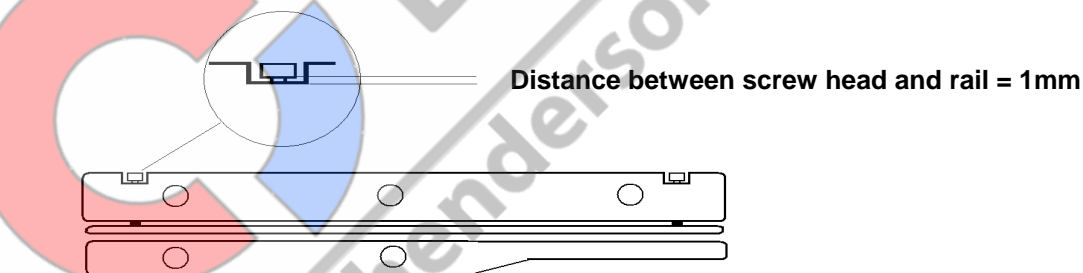

- Close housing

hm 850 DC-V	Troubleshooting and maintenance	Chapter 4
-------------	---------------------------------	-----------

4.9 Service settings

4.9.1 Activate service menu

<ol style="list-style-type: none"> 1. Switch off machine 2. Open housing cover 3. Remove service dongle 4. Plug service dongle into the COM1 connector (rear of machine) 5. Switch on machine 	<p>The diagram shows the rear panel of the machine with the housing cover removed. A 'Service Dongle' is shown being inserted into the COM 1 connector. The PC board is visible above the connectors. The connectors are labeled COM 2, KYB, and COM 1. A 'language GB' label is also visible.</p>
--	--

4.9.2 Adjusting contact pressure

<p>Press key after activating the Service menu</p> <p style="text-align: center;">OK</p> <ol style="list-style-type: none"> 1. Undo screw S until measurement M no longer changes 2. Use potentiometer P1 to set measured value M to 5 N 3. Set measured value M to 100 N by screwing in the screw S and confirm setting 	
---	--



4.9.3 Adjusting temperature control

1. Insert temperature sensor from the infeed side between the sealing dies

2. Activate the service menu and press the keys one after another

2x **OK** → **TEMP**

The temperatures 75°C , 125°C,175°C and 225°C are measured one after another and the difference between nominal value **Tn** and actual value **Ta** is corrected.

After a set temperature has been reached it is stabilized for 120s.

When 120s have elapsed the corrected value is input **Ta**

4.9.4 Setting the margin

1. Activate the service menu and press the keys one after another

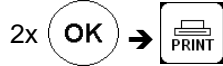

2. Insert package, dimension > 150 mm.
Two perpendicular lines are printed.

3. Acknowledge test printout

4. Measure distance 1 between the edge of the package and the first bar and enter the measurement in mm

5. Measure distance 2 between the edge of the package and the second bar and enter the measurement in mm

printer calibration test print

printer calibration test print

OK

printer calibration distance 1 25mm



OK

printer calibration distance 1 125mm







OK

hm 850 DC-V	Technical data	Chapter 5
-------------	----------------	-----------







4.9.5 Maintenance date entry

<p>1. Activate the service menu and press the keys one after another</p> <p>2x  → </p> <p>2. Enter date for the next maintenance reminder</p>	<div style="border: 1px solid black; padding: 5px; display: inline-block;">DD-MM-YY 12-11-10</div> 
---	--

4.9.6 Setting of the standby function

<p>1. Activate the service menu and press the keys one after another</p> <p>2x  → </p> <p>2. Enter the time for starting the standby function 0-120 min</p> <p>3. Activate or deactivate standby function</p>	<div style="border: 1px solid black; padding: 5px; display: inline-block;">stand by after 010 min</div>  <div style="border: 1px solid black; padding: 5px; display: inline-block;">stand by activate YES</div>  <div style="border: 1px solid black; padding: 5px; display: inline-block;">standby activate NO</div>  <div style="display: flex; align-items: center; margin-top: 10px;">  <div style="margin-left: 10px;"> <p>Yes If no sealings are performed, the set sealing temperature is reduced to 60°C after the entered time expires</p> </div> </div> <div style="display: flex; align-items: center;">  <div style="margin-left: 10px;"> <p>No Standby function not active</p> </div> </div>
---	---

4.9.7 Activation of default settings

<p>1. Activate the service menu and press the keys one after another</p> <p>2x  → </p> <p>2. Activate or deactivate default settings</p>	<div style="border: 1px solid black; padding: 5px; display: inline-block;">very first time YES</div>  <div style="border: 1px solid black; padding: 5px; display: inline-block;">very first time NO</div>  <div style="display: flex; align-items: center; margin-top: 10px;">  <div style="margin-left: 10px;"> <p>Yes If the default settings are activated then the following settings must be performed after the very first switch-on:</p> <p>Language Date and time Unit of measurement</p> </div> </div> <div style="display: flex; align-items: center;">  <div style="margin-left: 10px;"> <p>No No default setting needs to be performed after the very first switch-on.</p> </div> </div>
--	---

5 Technical data

5.1 Circuit diagram and wiring diagram

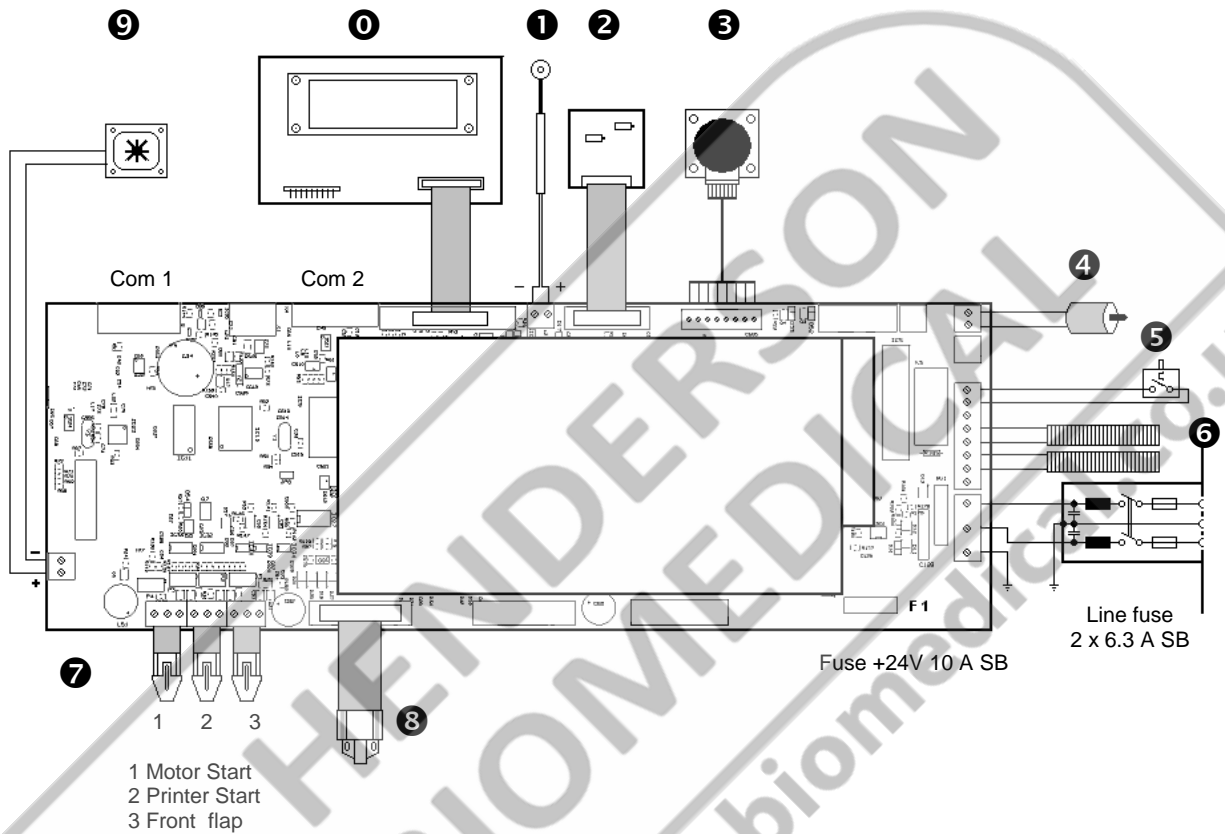

0	Indicator card	1.410.017
1	Temperature sensor	6.564.023
2	DMS module	1.410.018
3	Gear motor	1.212.011
4	Ink ribbon motor	1.212.012
5	Temperature switch	6.564.018
6	Heating cartridges 115V/200W	6.536.032
7	Optosensors	1.561.003
8	Print head	1.653.002
9	Fan	6.212.024

hm 850 DC-V	Technical data	Chapter 5
-------------	----------------	-----------

5.2 Specifications

Connection data

Power connection	[V]	100 - 240
Power frequency	[Hz]	50 / 60
Power consumption	max. [W]	400
Main fuse 100V – 240V	[A]	6,3 T

Mechanical system

Dimensions	Length	[mm]	710
including	Width		260
infeed section	Height		240
Housing cover	Stainless steel AISI 304		
Housing bottom	Metal, powder-coated		
Weight	[kg]		23
Sealed edge infinitely adjustable	[mm]		0 – 35
Sealing seam width	[mm]		12
sealing system	hawoflex™		
Length of sealing seam	[mm]		unlimited
Distance from medical product	[mm]		>30 (acc. to DIN 58953-7)

Process parameter / Sealing parameter

Sealing temperature	max. [°C]	220
Tolerance limit motor stop	[°C]	± 2 – ±5 (adjustable)
Contact pressure	[N]	100
Contact pressure deactivation tolerance	[%]	±20
Sealing speed	[m / min]	10
Deactivation tolerance		±10
Sealing speed	[%]	
Temperature ranges		3
Temperature control tolerance	[%]	±2

Electronics and communication systems

System	Microprocessor	
Interfaces:	RS-232 connector USB with adapter	yes available as option (art. no.: 1.596.024)
Data rate (baudrate)		9.600
Serial interface PC		
Electrical protection class		1

Environmental parameters

Environment temperature	[°C]	5-25
Heat dissipation	[kJ/s]	0,1
Noise intensity acc. to Machinery Directive 2006/42/EC Appendix I 1.7.4.2 u.)	[dB/ A]	<70

hm 850 DC-V	Declaration of Conformity	Chapter 6
-------------	---------------------------	-----------

6 Declarations of conformity

6.1 EC- Declaration of conformity

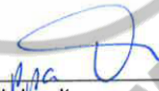
 74847 Obrigheim / Germany	Konformitätserklärung – Declaration of Conformity Déclaration "CE" de Conformité Declaración de conformidad de la C.E. Dichiarazione di conformità - Declaração de conformidade	0.992.060C																																																						
Gültig ab: 01.02.2015 Valid from:		Seite 1/1 Version 5.02																																																						
<p>Hiermit erklären wir, daß die Folienschweissmaschinen: Herewith we declare that the Foil sealing unit: Par la présente, nous déclarons que la gamme de Soudeuse de films plastique: Por la presente certificamos que las máquinas embolsadoras modelos: Dichiariamo con la presente che le macchine per saldatura di fogli: Por este meio se declara que as máquinas de selagem de folhas de plástico:</p> <p style="text-align: center;">hm 850 DC-V</p> <p>folgenden einschlägigen Bestimmungen und harmonisierten Normen entsprechen: complies with the requirements of the following regulations and harmonised standards: corresponde aux dispositions suivantes et standards harmonisés: objeto de esta Declaración cumple con las siguientes disposiciones: Sono conformi alle seguenti disposizioni in materia nonché alle seguenti norme armonizzate: correspondem às seguintes determinações e normas harmonizadas:</p> <table border="0" style="width: 100%;"> <tr> <td style="width: 33%;">EG - Maschinenrichtlinie</td> <td style="width: 33%;">2006/42/EG</td> <td style="width: 33%;"></td> </tr> <tr> <td>Machinery directive</td> <td></td> <td></td> </tr> <tr> <td>Directive "CE" rel. aux machines</td> <td></td> <td></td> </tr> <tr> <td>Directiva de Maquinaria de la CE</td> <td></td> <td></td> </tr> <tr> <td>Direttiva CE sulle macchine nella versione</td> <td></td> <td></td> </tr> <tr> <td>Directiva da UE relativa a maquinaria</td> <td></td> <td></td> </tr> <tr> <td>EMV-Richtlinie</td> <td>EMC-directive</td> <td>2014/30/EU</td> </tr> <tr> <td>Directive CEM</td> <td>Directiva da CEM</td> <td></td> </tr> <tr> <td>Direttiva CEM</td> <td>Directiva CEM</td> <td></td> </tr> <tr> <td>WEEE-Richtlinie</td> <td>WEEE--directive</td> <td>2012/19/EU</td> </tr> <tr> <td>Directive WEEE</td> <td>Directiva da WEEE</td> <td></td> </tr> <tr> <td>Direttiva WEEE</td> <td>Directiva WEEE</td> <td></td> </tr> <tr> <td>RoHS-Richtlinie</td> <td>RoHS-directive</td> <td>2011/65/EG</td> </tr> <tr> <td>Directive RoHS</td> <td>Directiva de RoHS</td> <td></td> </tr> <tr> <td>Direttiva RoHS</td> <td>Directiva RoHS</td> <td></td> </tr> <tr> <td>Harmonisierte Normen</td> <td>Harmonized standards</td> <td>EN ISO 12100/2010_07 EN 60204-1/2007_06</td> </tr> <tr> <td>Standard harmonisé</td> <td>Las normas armonizadas</td> <td>EN ISO 13857/2008_06 EN 61000-6-1/2007_10</td> </tr> <tr> <td>Norme armonizzate</td> <td>Normas harmonizadas</td> <td>EN 61000-6-3/2011_09</td> </tr> </table> <p>Verantwortliche Person für die Technischen Unterlagen siehe unten Responsible person for technical documentation see below La personne responsable pour la documentation technique est mentionnée au-dessous</p> <p style="text-align: center;">  Torsten Ehrhardt Prokurist / authorized officer </p> <p>hawa GmbH, Obere Au 2, D-74847 Obrigheim, Germany</p>			EG - Maschinenrichtlinie	2006/42/EG		Machinery directive			Directive "CE" rel. aux machines			Directiva de Maquinaria de la CE			Direttiva CE sulle macchine nella versione			Directiva da UE relativa a maquinaria			EMV-Richtlinie	EMC-directive	2014/30/EU	Directive CEM	Directiva da CEM		Direttiva CEM	Directiva CEM		WEEE-Richtlinie	WEEE--directive	2012/19/EU	Directive WEEE	Directiva da WEEE		Direttiva WEEE	Directiva WEEE		RoHS-Richtlinie	RoHS-directive	2011/65/EG	Directive RoHS	Directiva de RoHS		Direttiva RoHS	Directiva RoHS		Harmonisierte Normen	Harmonized standards	EN ISO 12100/2010_07 EN 60204-1/2007_06	Standard harmonisé	Las normas armonizadas	EN ISO 13857/2008_06 EN 61000-6-1/2007_10	Norme armonizzate	Normas harmonizadas	EN 61000-6-3/2011_09
EG - Maschinenrichtlinie	2006/42/EG																																																							
Machinery directive																																																								
Directive "CE" rel. aux machines																																																								
Directiva de Maquinaria de la CE																																																								
Direttiva CE sulle macchine nella versione																																																								
Directiva da UE relativa a maquinaria																																																								
EMV-Richtlinie	EMC-directive	2014/30/EU																																																						
Directive CEM	Directiva da CEM																																																							
Direttiva CEM	Directiva CEM																																																							
WEEE-Richtlinie	WEEE--directive	2012/19/EU																																																						
Directive WEEE	Directiva da WEEE																																																							
Direttiva WEEE	Directiva WEEE																																																							
RoHS-Richtlinie	RoHS-directive	2011/65/EG																																																						
Directive RoHS	Directiva de RoHS																																																							
Direttiva RoHS	Directiva RoHS																																																							
Harmonisierte Normen	Harmonized standards	EN ISO 12100/2010_07 EN 60204-1/2007_06																																																						
Standard harmonisé	Las normas armonizadas	EN ISO 13857/2008_06 EN 61000-6-1/2007_10																																																						
Norme armonizzate	Normas harmonizadas	EN 61000-6-3/2011_09																																																						
hawa GmbH Obere Au 2-4 74847 Obrigheim / Germany	T + 49 (0) 6261 / 9770-0 F + 49 (0) 6261 / 9770-69 info@hawa.com www.hawa.com	Amtsgericht Mannheim: HRB 441011 Geschäftsführer: Hans Wolf und Christian Wolf Firmensitz: Obrigheim																																																						
This document and the contents hereof are considered proprietary and confidential information of hawa and disclosure to unauthorized individuals or dissemination, publication, or copying is prohibited without prior written consent by hawa GmbH, 74847 Obrigheim, Germany.																																																								

hm 880 DC-V	Declaration of Conformity	Chapter 6
-------------	---------------------------	-----------

6.2 DIN EN ISO 11607-2 / DIN 58953-7 Declaration of conformity

 74847 Obrigheim / Germany	Konformitätserklärung – Declaration of Conformity Déclaration de Conformité Declaración de conformidad Dichiarazione di conformità - Declaração de conformidade	0.992.060D						
Gültig ab: 01.10.2012 Valid from:		Seite 1/1 Version 1.05						
<p>Hiermit erklären wir, daß die Folienschweißmaschinen: Herewith we declare that the Foil sealing unit: Par la présente, nous déclarons que la gamme de Soudeuse de films plastique: Por la presente certificamos que las máquinas embolsadoras modelos: Dichiariamo con la presente che le macchine per saldatura di fogli: Por este meio se declara que as máquinas de selagem de folhas de plástico:</p> <p style="text-align: center;">hm 850 DC-V</p> <p>folgenden einschlägigen Bestimmungen und harmonisierten Normen entsprechen: complies with the requirements of the following regulations and harmonised standards: corresponde aux dispositions suivantes et standards harmonisés: objeto de esta Declaración cumple con las siguientes disposiciones: Sono conformi alle seguenti disposizioni in materia nonché alle seguenti norme armonizzate: correspondem às seguintes determinações e normas harmonizadas:</p> <table border="0" style="width: 100%;"> <tr> <td style="width: 60%;">Anforderungen an die Hygiene bei der Aufbereitung von Medizinprodukten. Empfehlung der Kommission für Krankenhaushygiene und Infektionsprävention (KRINKO) beim Robert Koch-Institut (RKI) und des Bundesinstitutes für Arzneimittel und Medizinprodukte (BfArM)</td> <td style="width: 40%;">KRINKO / BfArM Bundesgesundheitsblatt 2012 55:1244-1310</td> </tr> <tr> <td>Verpackungen für in der Endverpackung zu sterilisierende Medizinprodukte – Teil 2: Validierungsanforderungen an Prozesse der Formgebung, Siegelung und des Zusammenstellens Packaging for terminally sterilized medical devices – Part 2: Validation requirements for forming, sealing and assembly processes Emballages des dispositifs médicaux stérilisés au stade terminal – Partie 2: Exigences relatives aux procédés de mise en forme, de fermeture et d'assemblage</td> <td>DIN EN ISO 11607-2:2006 ANSI/AAMI/ISO 11607-2:2006</td> </tr> <tr> <td>Sterilisation – Sterilgutversorgung – Teil 7: Anwendungstechnik von Sterilisationspapier, Vliesstoffen, gewebten textilen Materialien, Papierbeuteln und siegelfähigen Klarsichtbeuteln und -schläuchen Sterilization – Sterile supply – Part 7: Use of sterilization paper, nonwoven wrapping material, textile materials, paper bags and sealable pouches and reels Stérilisation – Approvisionnement en produits stériles – Partie 7: Utilisation de papier pour stérilisation, de matériaux d'enveloppe en non-tissé, matériaux textiles tissés, de sacs en papier, de sachets et gaines scellables</td> <td>DIN 58953-7:2010</td> </tr> </table> <p style="text-align: right;">  Torsten Ehrhardt Prokurist / authorized officer hawa GmbH, Obere Au 2, D-74847 Obrigheim, Germany </p>			Anforderungen an die Hygiene bei der Aufbereitung von Medizinprodukten. Empfehlung der Kommission für Krankenhaushygiene und Infektionsprävention (KRINKO) beim Robert Koch-Institut (RKI) und des Bundesinstitutes für Arzneimittel und Medizinprodukte (BfArM)	KRINKO / BfArM Bundesgesundheitsblatt 2012 55:1244-1310	Verpackungen für in der Endverpackung zu sterilisierende Medizinprodukte – Teil 2: Validierungsanforderungen an Prozesse der Formgebung, Siegelung und des Zusammenstellens Packaging for terminally sterilized medical devices – Part 2: Validation requirements for forming, sealing and assembly processes Emballages des dispositifs médicaux stérilisés au stade terminal – Partie 2: Exigences relatives aux procédés de mise en forme, de fermeture et d'assemblage	DIN EN ISO 11607-2:2006 ANSI/AAMI/ISO 11607-2:2006	Sterilisation – Sterilgutversorgung – Teil 7: Anwendungstechnik von Sterilisationspapier, Vliesstoffen, gewebten textilen Materialien, Papierbeuteln und siegelfähigen Klarsichtbeuteln und -schläuchen Sterilization – Sterile supply – Part 7: Use of sterilization paper, nonwoven wrapping material, textile materials, paper bags and sealable pouches and reels Stérilisation – Approvisionnement en produits stériles – Partie 7: Utilisation de papier pour stérilisation, de matériaux d'enveloppe en non-tissé, matériaux textiles tissés, de sacs en papier, de sachets et gaines scellables	DIN 58953-7:2010
Anforderungen an die Hygiene bei der Aufbereitung von Medizinprodukten. Empfehlung der Kommission für Krankenhaushygiene und Infektionsprävention (KRINKO) beim Robert Koch-Institut (RKI) und des Bundesinstitutes für Arzneimittel und Medizinprodukte (BfArM)	KRINKO / BfArM Bundesgesundheitsblatt 2012 55:1244-1310							
Verpackungen für in der Endverpackung zu sterilisierende Medizinprodukte – Teil 2: Validierungsanforderungen an Prozesse der Formgebung, Siegelung und des Zusammenstellens Packaging for terminally sterilized medical devices – Part 2: Validation requirements for forming, sealing and assembly processes Emballages des dispositifs médicaux stérilisés au stade terminal – Partie 2: Exigences relatives aux procédés de mise en forme, de fermeture et d'assemblage	DIN EN ISO 11607-2:2006 ANSI/AAMI/ISO 11607-2:2006							
Sterilisation – Sterilgutversorgung – Teil 7: Anwendungstechnik von Sterilisationspapier, Vliesstoffen, gewebten textilen Materialien, Papierbeuteln und siegelfähigen Klarsichtbeuteln und -schläuchen Sterilization – Sterile supply – Part 7: Use of sterilization paper, nonwoven wrapping material, textile materials, paper bags and sealable pouches and reels Stérilisation – Approvisionnement en produits stériles – Partie 7: Utilisation de papier pour stérilisation, de matériaux d'enveloppe en non-tissé, matériaux textiles tissés, de sacs en papier, de sachets et gaines scellables	DIN 58953-7:2010							
hawa GmbH Obere Au 2-4 74847 Obrigheim / Germany	T + 49 (0) 6261 / 9770-0 F + 49 (0) 6261 / 82015 info@hawa.com www.hawa.com	Amtsgericht Mannheim: HRB 441011 Geschäftsührer: Hans Wolf und Christian Wolf Firmensitz: Obrigheim						

s. 9/10 007_Mannheim 2 01

hm 880 DC-V	Validation	Chapter 7
-------------	------------	-----------

7 Validation

7.1 General

The main purpose of every packaging system for medical products, which are sterilised during the final packaging, is maintaining the sterility until use or until aseptic preparation at the patient. The validation of packaging processes is crucial to ensure that sterile barrier system integrity is attained and will remain so until opened by the users of sterile medical machines.

Within the scope of the preparation of medical products, the sealing process is considered to be part of the process chain. This process is also to be validated in accordance with the Law on Medical Products and with the Medical Machines Operator Ordinance.

The international standard EN ISO 11607 – Part 2 requires and describes the validation of packaging processes. In order to implement it, the German Society for Sterile Supply (Deutsche Gesellschaft für Sterilgutversorgung) issued a Guideline for the Validation of Sealing Processes according to EN ISO 11607-2.

The machine meets the requirements of EN ISO 11607-2 and the resulting DGSV guideline for sealing process validation.

The guideline can be downloaded from the www.dgsv-leitlinie.de website, or it can be requested from the hawo Service Line on +49 (0) 6261 9770 0 (keyword: DGSV guideline).

Validation must always be performed by the user at the installation site.

7.2 Preparation

Your sealing machine has already been calibrated before delivery (see test report). The sealing machine should be re-calibrated before each re-validation.

The manufacturer's calibration of hawo sealing machines may only be performed by hawo GmbH or by one of hawo's authorised service partners. For further information, please contact your authorised service partner or the hawo Service Hotline: +49 (0) 6261 9770 0 (keyword: Maintenance and calibration).

The manufacturer's calibration must be ordered separately (order number 9.079.035) and is **not** included in shipment!

Furthermore, for the operational qualification you need the hawotest SEAL CHECK indicators. You can obtain these from your supplier or directly from hawo (online at www.seal-check.de).

Using the original hawotest SEAL CHECK is recommended.

hm 850 DC-V	Validation	Chapter 7
-------------	------------	-----------

7.3 Validation

We recommend that you perform validation in accordance with the DGSV* guideline for validation (available from www.dgsv-leitlinie.de). In the following section you will find useful information, which you will need to implement the DGSV guideline.

* German Society for Sterile Supply DGSV

7.3.1 Validation schedule information

7.3.1.1 Description of the sealing machine

Your sealing machine is a rotary sealer. The precise name and the serial number are written on the type plate attached on a side of the machine.

The required disconnection tolerance (A) is $\pm 5\text{ °C}$ ($\pm 9\text{ °F}$) according to DIN 58953-7.

The temperature range of the packaging material will be required again later in the process. You can get this information from your material supplier. If you do not succeed in getting this information, you can take as a rule the following ranges:

Transparent packages according to EN 868-5:	170 – 190 °C
Uncoated HDPE (Tyvek™):	130 – 140 °C

(when using uncoated HDPE materials (e.g. Tyvek™) the deactivation tolerance must be reduced if necessary)

7.3.1.2 Installation qualification information (IQ)

7.3.1.2.1 QM-system

You can get from hawo free of charge the necessary certificate for the quality management system ISO 9001:2000.

Ask for it from info@hawo.com or call us on: +49 (0) 6261 9770 0 (keyword: QM certificate)

7.3.1.2.2 Type of machine: Rotary sealer

The machine has CE marking and complies with the EN ISO 11607-2 and DIN 58953-7 standards. The corresponding conformity declarations can be found in chapter 6 and serve as certifying proof.

7.3.1.2.3 Service authorisation

The service partner must be authorised by hawo in writing. Ask your service team for the certificate.

hm 850 DC-V	Validation	Chapter 7
-------------	------------	-----------

7.3.1.2.4 Safety features

Parameters	required	existing
Sealing seam width	6 mm*	12 mm
Distance from medical product	30 mm*	30 mm
Process cycle	automatic	automatic

* required in DIN 58953-7

7.3.1.2.5 Critical parameters

Parameters	Disconnection tolerance preset	adjustable
Sealing temperature	+/- 5°C *	+/- 2 - 5°C***
Contact pressure	+/- 20% of the set value	not possible
Sealing speed	+/- 10% of the set value	not possible

* required in DIN 58953-7

*** when using uncoated HDPE materials (e.g. Tyvek™), the required disconnection tolerance of +/- 5°C may not be sufficient

These are controlled and monitored by the microprocessor system.

Systems have been integrated which, in case of deviation of the predetermined limit values from the process parameters, display warnings and stop the machine.

This prevents further working.

The process parameters must be routinely monitored. For this hawo offers the following possibilities:

1. SEAL CHECK function
Daily printout of the sealing parameters with SEAL CHECK function (also refer to section 3.10 for information).
2. ht 180 PT-USB (order number 0.712.005)
The new hawotest ht 180 PT-USB is a mobile process documentation system. This system automatically receives data about the process parameters and additional relevant protocol data (machine number, staff number, etc.). The data is stored on a USB stick and transferred to a PC. Storage occurs by means of digitally signed PDF documents directly on the PC.
3. Batch documentation systems
The machines can be connected through an interface directly to the batch documentation system. Ask the producer for the exact compatibilities.
- 4.

hm 850 DC-V	Validation	Chapter 7
-------------	------------	-----------

7.3.1.3 Operational qualification information (OQ)

According to standard EN ISO 11607-2, section 5.3.2 b, the quality characteristics of the sealing are the following:

- Intact sealing across the entire sealing seam width
- No channels or open seals
- No punctures or tears
- No delamination or material separation

These quality characteristics must be checked and documented with a suitable method. Quality characteristics can be checked in the best way using the hawotest SEAL CHECK indicators.

The SEAL CHECK reference card from hawo gives clear statements about their implementation.

For this purpose, a sealing must be made at the lower and upper limit value of the sealing temperature. Quality characteristics are to be fulfilled in both sealings.

After that the sealing temperature is to be determined for daily practice. It is recommended to form these from middle of the ACTUAL temperatures (during the test; e.g. a lower limit according to the manufacturer of 170 °C (338 °F) and an upper limit according to the manufacturer of 190 °C (374 °F), mean value = sealing value 180 °C (356 °F).

7.3.1.4 Performance qualification information (PQ)

With the performance qualification it is to be furnished proof of a good understanding of the process and of delivering of optimal closed sterile barrier systems - also after the sterilisation. The test is performed by determining the seal strength acc. to DIN EN 868-5, Annex D. The packages must be sterilised before the test. Records (batch documentation) of sterilisation processes are part of the validation.

For the combinations determined in the validation schedule (see also Appendix E of the DGSV guideline) 3 pouches of the same material must be sealed each time at the defined temperature (T) and subsequently sterilised using the predefined sterilisation program (reels must be sealed on both sides). Each pouch is to be attributed to a different sterilisation batch (if available) in order to consider all influencing variables in the sterilisation batches.

Seal seam resistance must be determined by a qualified validator (e.g. directly by hawo GmbH or by an authorised service partner). Contact us now to ask us for the necessary documents and checklists (order number 9.079.036).

hm 850 DC-V	Validation	Chapter 7
-------------	------------	-----------

7.3.1.5 Revalidation

Since even small changes can frequently compromise the validation status, the processes must be revalidated periodically if changes have been made to the sealing machine or if the packaging material has been changed.

As the manufacturer, we recommend annual periodic revalidation. If no changes have been made to the sealing machine and the material has not been modified, a repetition of the performance qualification (repeat of seal seam resistance determination) is sufficient for revalidation.

Seal seam resistance must be determined by a qualified validator (e.g. directly by hawo GmbH or by an authorised service partner). Contact us now to ask us for the necessary documents and checklists (order number 9.079.036).

The sealing machine must be serviced and demonstrably calibrated before periodic revalidation.

Servicing and calibration of hawo sealing machines may only be performed by hawo GmbH or by one of hawo's authorised service partners. For further information, please contact your authorised service partner or the hawo Service Hotline: +49 (0) 6261 9770 0 (keyword: Maintenance and calibration)



LABORATORY EQUIPMENT MAINTENANCE, REPAIR, CALIBRATION AND SALES

Established in 1987, Henderson Biomedical is the UK's leading laboratory equipment sales and service provider. Our knowledgeable team can provide you with excellent sales advice on a range of different types of laboratory equipment including centrifuges, refrigerators, freezers and heat sealers.

Henderson Biomedical is also able to provide you with first class after-sales service and calibration of your laboratory equipment. We are an **ISO 17025 (UKAS) accredited calibration test laboratory** and our team of Field Service Engineers cover the whole of the United Kingdom.

Please contact us for more information on the types of equipment we supply and the different after-sales services we can offer.

Henderson Biomedical

Unit 3, Swan Close
Croydon CR0 2DZ
United Kingdom

Tel: 020 8663 4610

For sales enquiries: sales@henderson-biomedical.co.uk
For all other enquiries: info@henderson-biomedical.co.uk
www.henderson-biomedical.co.uk

